

POINT I/O 2 Current Output and 2 Voltage Output Analog Modules

Catalog Numbers 1734-OE2C, 1734-OE2V, Series C

Table of Contents

Topic	Page
Important User Information	2
Environment and Enclosure	3
Preventing Electrostatic Discharge	3
North American Hazardous Location Approval	4
European Hazardous Location Approval	5
Before You Begin	6
Identify Module Components	6
Install the Mounting Base	7
Install the Module	7
Install the Removable Terminal Block (RTB)	8
Remove a Mounting Base	9
Communicate with Your Module	10
Wire the Module	11
Troubleshoot with Indicators	14
Placing Series C Analog Current Output Modules	16
Specifications	18

Important User Information

Solid-state equipment has operational characteristics differing from those of electromechanical equipment. Safety Guidelines for the Application, Installation and Maintenance of Solid State Controls (Publication [SGI-1.1](#) available from your local Rockwell Automation sales office or online at <http://www.rockwellautomation.com/literature/>) describes some important differences between solid-state equipment and hard-wired electromechanical devices. Because of this difference, and also because of the wide variety of uses for solid-state equipment, all persons responsible for applying this equipment must satisfy themselves that each intended application of this equipment is acceptable.





In no event will Rockwell Automation, Inc. be responsible or liable for indirect or consequential damages resulting from the use or application of this equipment.

The examples and diagrams in this manual are included solely for illustrative purposes. Because of the many variables and requirements associated with any particular installation, Rockwell Automation, Inc. cannot assume responsibility or liability for actual use based on the examples and diagrams.

No patent liability is assumed by Rockwell Automation, Inc. with respect to use of information, circuits, equipment, or software described in this manual.

Reproduction of the contents of this manual, in whole or in part, without written permission of Rockwell Automation, Inc., is prohibited.

Throughout this manual, when necessary, we use notes to make you aware of safety considerations.

	WARNING: Identifies information about practices or circumstances that can cause an explosion in a hazardous environment, which may lead to personal injury or death, property damage, or economic loss.
	ATTENTION: Identifies information about practices or circumstances that can lead to personal injury or death, property damage, or economic loss. Attentions help you identify a hazard, avoid a hazard and recognize the consequences.
	SHOCK HAZARD: Labels may be on or inside the equipment (for example, drive or motor) to alert people that dangerous voltage may be present.
	BURN HAZARD: Labels may be on or inside the equipment (for example, drive or motor) to alert people that surfaces may reach dangerous temperatures.
IMPORTANT	Identifies information that is critical for successful application and understanding of the product.

Environment and Enclosure



ATTENTION: This equipment is intended for use in a Pollution Degree 2 industrial environment, in overvoltage Category II applications (as defined in IEC publication 60664-1), at altitudes up to 2000 meters without derating. This equipment is not intended for use in residential environments and may not provide adequate protection to radio communication services in such environments.

This equipment is considered Group 1, Class A industrial equipment according to IEC/CISPR Publication 11. Without appropriate precautions, there may be potential difficulties ensuring electromagnetic compatibility in other environments due to conducted as well as radiated disturbance.

This equipment is supplied as “open type” equipment. It must be mounted within an enclosure that is suitably designed for those specific environmental conditions that will be present and appropriately designed to prevent personal injury resulting from accessibility to live parts. The interior of the enclosure must be accessible only by the use of a tool. Subsequent sections of this publication may contain additional information regarding specific enclosure type ratings that are required to comply with certain product safety certifications. In addition to this publication, see:

- Industrial Automation Wiring and Grounding Guidelines, publication [1770-4.1](#), for additional installation requirements.
- NEMA Standard 250 and IEC 60529, as applicable, for explanations of the degrees of protection provided by enclosures.



Preventing Electrostatic Discharge



ATTENTION: This equipment is sensitive to electrostatic discharge, which can cause internal damage and affect normal operation. Follow these guidelines when you handle this equipment:

- Touch a grounded object to discharge potential static.
 - Wear an approved grounding wriststrap.
 - Do not touch connectors or pins on component boards.
 - Do not touch circuit components inside the equipment.
 - Use a static-safe workstation, if available.
 - Store the equipment in appropriate static-safe packaging when not in use.
-

North American Hazardous Location Approval

<p>The following information applies when operating this equipment in hazardous locations:</p>	<p>Informations sur l'utilisation de cet équipement en environnements dangereux:</p>
<p>Products marked "CL I, DIV 2, GP A, B, C, D" are suitable for use in Class I Division 2 Groups A, B, C, D, Hazardous Locations and nonhazardous locations only. Each product is supplied with markings on the rating nameplate indicating the hazardous location temperature code. When combining products within a system, the most adverse temperature code (lowest "T" number) may be used to help determine the overall temperature code of the system. Combinations of equipment in your system are subject to investigation by the local Authority Having Jurisdiction at the time of installation.</p>	<p>Les produits marqués "CL I, DIV 2, GP A, B, C, D" ne conviennent qu'à une utilisation en environnements de Classe I Division 2 Groupes A, B, C, D dangereux et non dangereux. Chaque produit est livré avec des marquages sur sa plaque d'identification qui indiquent le code de température pour les environnements dangereux. Lorsque plusieurs produits sont combinés dans un système, le code de température le plus défavorable (code de température le plus faible) peut être utilisé pour déterminer le code de température global du système. Les combinaisons d'équipements dans le système sont sujettes à inspection par les autorités locales qualifiées au moment de l'installation.</p>
<div style="display: flex; align-items: center;">  <div> <p>EXPLOSION HAZARD</p> <ul style="list-style-type: none"> • Do not disconnect equipment unless power has been removed or the area is known to be nonhazardous. • Do not disconnect connections to this equipment unless power has been removed or the area is known to be nonhazardous. Secure any external connections that mate to this equipment by using screws, sliding latches, threaded connectors, or other means provided with this product. • Substitution of components may impair suitability for Class I, Division 2. • If this product contains batteries, they must only be changed in an area known to be nonhazardous. </div> </div>	<div style="display: flex; align-items: center;">  <div> <p>RISQUE D'EXPLOSION</p> <ul style="list-style-type: none"> • Couper le courant ou s'assurer que l'environnement est classé non dangereux avant de débrancher l'équipement. • Couper le courant ou s'assurer que l'environnement est classé non dangereux avant de débrancher les connecteurs. Fixer tous les connecteurs externes reliés à cet équipement à l'aide de vis, loquets coulissants, connecteurs filetés ou autres moyens fournis avec ce produit. • La substitution de composants peut rendre cet équipement inadapté à une utilisation en environnement de Classe I, Division 2. • S'assurer que l'environnement est classé non dangereux avant de changer les piles. </div> </div>

European Hazardous Location Approval

The following applies when the product bears the Ex Marking

This equipment is intended for use in potentially explosive atmospheres as defined by European Union Directive 94/9/EC.

DEMKO certifies that this equipment has been found to comply with the Essential Health and Safety Requirements relating to the design and construction of Category 3 equipment intended for use in Zone 2 potentially explosive atmospheres, given in Annex II to this Directive.

Compliance with the Essential Health and Safety Requirements has been assured by compliance with EN 60079-0:2012+A11:2013, EN 60079-15:2010, reference certificate number DEMKO 04ATEX0330347X.



ATTENTION: This equipment is not resistant to sunlight or other sources of UV radiation.



WARNING: This equipment shall be mounted in an ATEX certified enclosure with a minimum ingress protection rating of at least IP54 (as defined in IEC60529) and used in an environment of not more than Pollution Degree 2 (as defined in IEC 60664-1) when applied in Zone 2 environments. The enclosure must utilize a tool removable cover or door.

WARNING: This equipment shall be used within its specified ratings defined by Rockwell Automation.

WARNING: Provision shall be made to prevent the rated voltage from being exceeded by transient disturbances of more than 140% of the rated voltage when applied in Zone 2 environments.

WARNING: The secondary of a current transformer shall not be open-circuited when applied in Class I, Zone 2 environments.

WARNING: This equipment must be used only with ATEX certified Rockwell Automation backplanes

WARNING: Secure any external connections that mate to this equipment by using screws, sliding latches, threaded connectors, or other means provided with this product.

WARNING: Do not disconnect equipment unless power has been removed or the area is known to be nonhazardous.

Before You Begin

You can use these Series C modules with DeviceNet and PROFIBUS adapters. If you are using RSLogix 5000 software, version 11 or higher, you can also use the Series C modules with ControlNet and Ethernet adapters.

Identify Module Components

Use the figure to identify the external features of the modules.

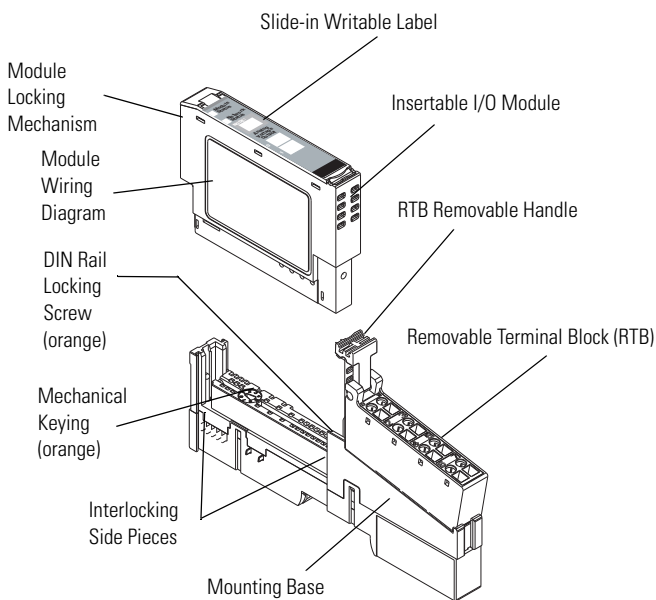

43931

The wiring base assembly includes terminal base, 1734-TB or 1734-TBS, which consists of mounting base, 1734-MB, and removable terminal block, 1734-RTB or 1734-RTBS.

Install the Mounting Base

To install the mounting base on the DIN rail, proceed as follows.



ATTENTION: This product is grounded through the DIN rail to chassis ground. Use zinc plated yellow-chromate steel DIN rail to assure proper grounding. The use of other DIN rail materials (for example, aluminum or plastic) that can corrode, oxidize, or are poor conductors, can result in improper or intermittent grounding. Secure DIN rail to mounting surface approximately every 200 mm (7.8 in.) and use end-anchors appropriately.

1. Position the mounting base vertically above the installed units (adapter, power supply, or existing module).
 2. Slide the mounting base down to make the interlocking side pieces engage the adjacent module or adapter.
 3. Press firmly to seat the mounting base on the DIN rail.
The mounting base will snap into place.
-



ATTENTION: Do not discard the end cap. Use this end cap to cover the exposed interconnections on the last mounting base on the DIN rail. Failure to do so could result in equipment damage or injury from electric shock.

Install the Module



ATTENTION: When you insert or remove the module while backplane power is on, an electrical arc can occur. This could cause an explosion in hazardous location installations.

Be sure that power is removed or the area is nonhazardous before proceeding. Repeated electrical arcing causes excessive wear to contacts on both the module and its mating connector. Worn contacts may create electrical resistance that can affect module operation.

Install the module before or after base installation. Make sure that you:

- correctly keyed the mounting base before installing the module into the mounting base

8 POINT I/O 2 Current Output and 2 Voltage Output Analog Modules

- positioned the mounting base locking screw horizontal with reference to the base

To install the module proceed as follows.

1. Using a bladed screwdriver, rotate the keyswitch on the mounting base clockwise until the number required for the type of module you are installing aligns with the notch in the base.
2. Make certain the DIN rail locking screw is in the horizontal position. You cannot insert the module if you have unlocked the locking mechanism.
3. Insert the module straight down into the mounting base and press to secure. The module will lock into place.

Install the Removable Terminal Block (RTB)

A removable terminal block comes with your wiring base assembly. To remove, pull up on the RTB handle. You can now remove the mounting base and replace as necessary without removing any of the wiring. To reinsert the removable terminal block, proceed as follows.

1. Insert the end opposite the handle into the base unit.
This end has a curved section that engages with the wiring base.
2. Rotate the terminal block into the wiring base until it locks itself in place.
3. If an I/O module is installed, snap the RTB handle into place on the module.



WARNING: When you connect or disconnect the Removable Terminal Block (RTB) with field side power applied, an electrical arc can occur. This could cause an explosion in hazardous location installations.

Be sure that power is removed or the area is nonhazardous before proceeding.

Remove a Mounting Base

To remove a mounting base, you must remove any installed module, and the module installed in the base to the right. Remove the removable terminal block, if wired.

1. Unlatch the RTB handle on the I/O module.
2. Pull on the RTB handle to remove the removable terminal block.



WARNING: When you connect or disconnect the Removable Terminal Block (RTB) with field side power applied, an electrical arc can occur. This could cause an explosion in hazardous location installations. Be sure that power is removed or the area is nonhazardous before proceeding.

-
3. Press on the module lock on the top of the module.
 4. Pull on the I/O module to remove from the base.



ATTENTION: When you insert or remove the module while backplane power is on, an electrical arc can occur. This could cause an explosion in hazardous location installations.

Be sure that power is removed or the area is nonhazardous before proceeding. Repeated electrical arcing causes excessive wear to contacts on both the module and its mating connector. Worn contacts may create electrical resistance that can affect module operation.

-
5. Repeat steps 1, 2, 3, and 4 for the module to the right.
 6. Use a small-bladed screwdriver to rotate the orange, base locking screw to a vertical position.
This releases the locking mechanism.
 7. Lift straight up to remove.

Communicate with Your Module

POINT I/O modules send (consume) and receive (produce) I/O messages. You map these messages into the processor's memory.

These modules produce 2 bytes of input data (scanner Rx) (fault status). These modules consume 4 bytes of output data (scanner Tx).

Message size: 2 Bytes

	15	14	13	12	11	10	09	08	07	06	05	04	03	02	01	00
Produces (scanner Rx)	High Byte - Channel 1 Status								Low Byte - Channel 0 Status							
	Not used				H C A	LC A	C M	C F	Not used				H C A	L C A	C M	C F

Where:

CF = Channel Fault status; 0 = no error, 1 = fault

CM = Calibration Mode; 0 = normal, 1 = calibration mode

HCA = High Clamp Alarm; 0 = no error, 1 = fault

LCA = Low Clamp Alarm; 0 = no error, 1 = fault

Message size: 4 bytes

	15	14	13	12	11	10	09	08	07	06	05	04	03	02	01	00
Consumes (scanner Tx)	Output Channel 0 High Byte								Output Channel 0 Low Byte							
	Output Channel 1 High Byte								Output Channel 1 Low Byte							

Wire the Module



WARNING: If you connect or disconnect wiring while the field-side power is on, an electrical arc can occur. This could cause an explosion in hazardous location installations. Be sure that power is removed or the area is nonhazardous before proceeding.

1734-OE2C POINT I/O 2 Current Output Analog Module

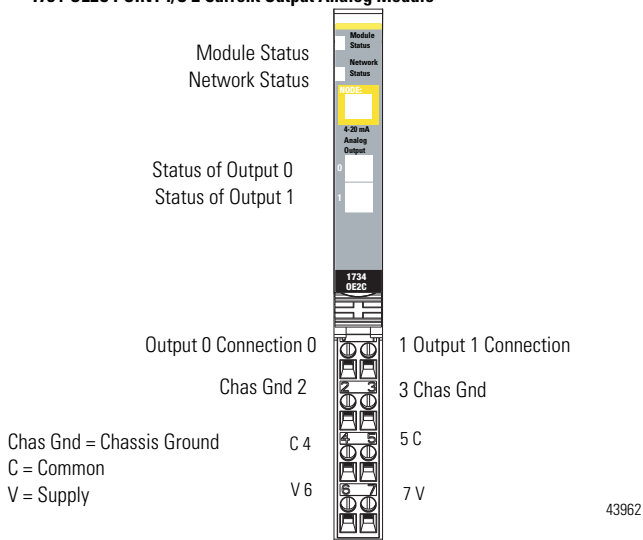

12 POINT I/O 2 Current Output and 2 Voltage Output Analog Modules

1734-0E2C POINT I/O 2 Current Output Analog Module

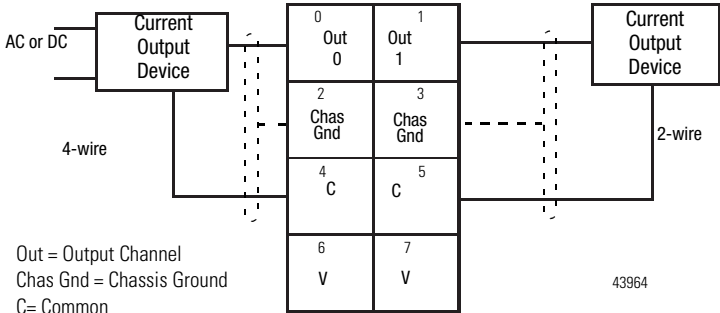

Channel	Current Output	Chassis Ground	Common	Supply
0	0	2	4	6
1	1	3	5	7

12/24V DC power is provided by the internal field power bus.

1734-0E2V POINT I/O 2 Voltage Output Analog Module

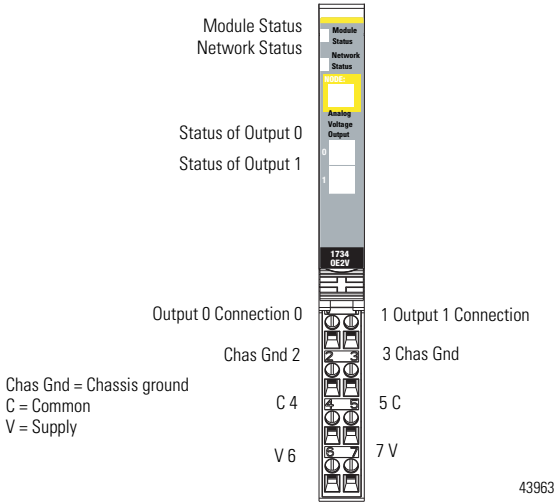

1734-0E2V POINT I/O 2 Voltage Output Analog Module

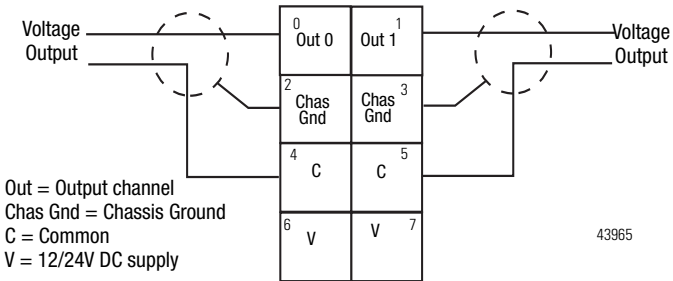

14 POINT I/O 2 Current Output and 2 Voltage Output Analog Modules

Channel	Voltage Output	Chassis Ground	Common	Supply
0	0	2	4	6
1	1	3	5	7

12/24V DC power is provided by the internal field power bus.

Troubleshoot with Indicators

Use the status indicators and tables to troubleshoot your module.

1734-0E2C POINT I/O 2 Current Output Analog Module

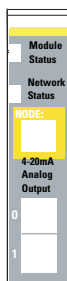

Module Status

Network Status

Status of Output 0

Status of Output 1

43962

1734-0E2V POINT I/O 2 Voltage Output Analog Module



Module Status

Network Status

Status of Output 0

Status of Output 1

43963

Module Status

Indication	Probable Cause
Off	No power is applied to device.
Green	Device is operating normally.
Flashing Green	Device needs commissioning due to configuration missing, incomplete, or incorrect.
Flashing Red	Recoverable fault is present.
Red	Unrecoverable fault may require device replacement.
Flashing Red/Green	Device is in self-test.

Network Status

Indication	Probable Cause
Off	Device is not online. - Device has not completed dup_MAC_id test. - Device not powered. Check module status indicator.
Flashing Green	Device is online but has no connections in the established state.
Green	Device is online and has connections in the established state.
Flashing Red	One or more I/O connections are in timed-out state
Red	Critical link failure is present with failed communication device. Device detected error that prevents it communicating on the network.
Flashing Red/Green	Communication faulted device is present. The device detected a network access error and is in communication faulted state. Device received and accepted an Identify Communication Faulted Request - long protocol message.

Channel Status

Indication	Probable Cause 1734-OE2C	Probable Cause 1734-OE2V
Off	Module is in CAL mode.	
Green	Normal operation is present with channel actively controlling outputs.	

Channel Status

Indication	Probable Cause 1734-OE2C	Probable Cause 1734-OE2V
Flashing Green	Channel is being calibrated.	
Flashing Red	Open wire or no field power is present.	A low or high clamp is present.
Red	-	No field power is present.

Placing Series C Analog Current Output Modules

Always install modules in accordance with their specified operating temperature ratings, as listed in [Specifications on page 18](#), and provide a minimum of 2.54 cm (1.0 in.) clearance above the modules.

- Limit the surrounding air temperature to 55 °C (131 °F).

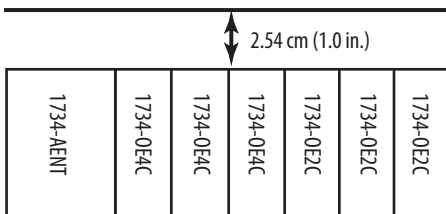
Placing Modules in Surrounding Air Temperature of 55 °C (131 °F) max

- If the module surface temperature is 70 °C (158 °F) or higher, insert a 1734-CTM spacer module next to each module when operating in surrounding air temperature of 25 °C (77 °F) to 55 °C (131 °F).

Placing Modules with Surface Temperature of 70 °C (158 °F) or Higher

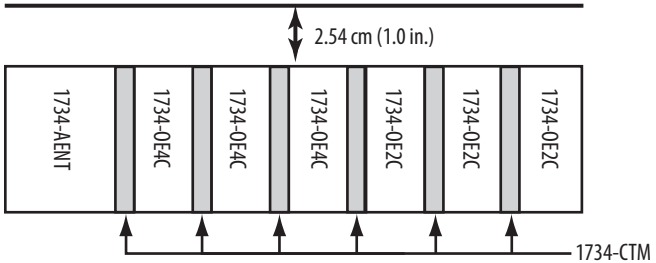

In this setup, the module will operate with two channels in surrounding air temperature of 25 °C (77 °F) to 40 °C (104 °F), and with only one channel in surrounding temperature of 41 °C (105.8 °F) to 55 °C (131 °F).

Refer to the following graph for details:

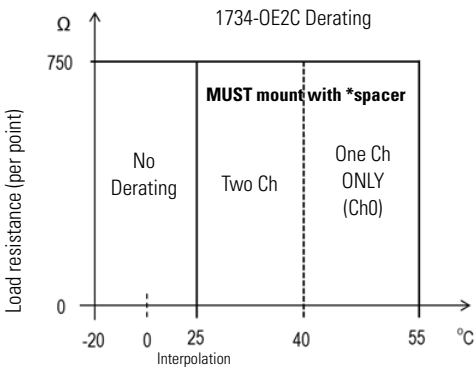

1 inch surrounding temperature of module

*Spacer:
1734-CTM or 1734-VTM

- Install forced ventilation in non-ventilated cabinets to help reduce the surrounding air temperature.
- Limit the power supply to 24V DC to help reduce the module's thermal dissipation.

Specifications

Output Specifications

Output Specifications	1734-0E2C	1734-0E2V
Number of Outputs	2 single-ended, non-isolated	
Resolution	13 bits - over 0-21mA 2.5 μ A/cnt (average value - typical range: 2.3...2.7 μ A/cnt)	14 bits (13 plus sign) 1.28mV/cnt in unipolar or bipolar mode
Output Current	0mA output until communication established 4-20mA user configurable 0-20mA user configurable	-
Output Voltage	-	0V output until communication established 0-10V (user configurable) (-0.0V under, +0.5V over) \pm 10V user configurable (-0.5V under, +0.5V over)
Absolute Accuracy ⁽¹⁾	Current Output 0.1% Full Scale @ 25°C	Voltage Output 0.1% Full Scale @ 25°C
Accuracy Drift w/Temp.	30ppm/°C	5ppm/°C
Step Response to 63% of FS	24 μ s	
Current Load on Voltage Output	-	3mA
Resistive Load on Current Output	0...750 Ω	-
Conversion Type	Digital to analog converter	
Conversion Rate	16 μ s	20 μ s
Data Format	Signed Integer	
Calibration	Factory Calibrated	

⁽¹⁾ Includes offset, gain, non-linearity and repeatability error terms.

General Specifications

Attribute	1734-0E2C	1734-0E2V
Module Location	1734-TB, 1734-TBS, 1734-TB3, 17340TB3S wiring base assembly	
POINTBus Current	75 mA @5V DC	
Power Dissipation - Maximum at 28.8V	750 Ω load on each output - 1.23 W 0 Ω load on each output - 1.83 W	1.0W
Thermal Dissipation - Maximum at 28.8V	750 Ω load on each output - 4.19 BTU/hr 0 Ω load on each output - 6.24 BTU/hr	3.4BTU/hr
Isolation Voltage (Continuous-voltage Withstand Rating)	50V Continuous Tested to withstand 2200V DC for 60 s No isolation between individual channels	
External DC power Supply Voltage Voltage Range Supply Current	24V DC nominal 10...28.8V DC 70 mA @ 24V DC (including outputs @20 mA)	24V DC nominal 10...28.8V DC 35 mA @ 24V DC (including outputs @3 mA)
Indicators	1 green/red module status indicator, logic side 1 green/red network status indicator, logic side 2 green/red output status indicators, logic side	
Keyswitch Position	4	
Dimensions	H x W x L 56 x 12 x 75.5 mm (2.21 x 0.47 x 2.97 in)	
Enclosure Type Rating	None (open-style)	
Wire Size	14 AWG (2.5mm ²) - 22 AWG (0.25mm ²) solid or stranded copper wire rated at 75 °C or greater 3/64 inch (1.2 mm) insulation maximum	
Wire Category ⁽¹⁾	1 - on signal ports	
Terminal Base Screw Torque	0.6 Nm (7 lb-in)	
Weight	0.036 kg (0.08 lb)	

⁽¹⁾ Use this Conductor Category information for planning conductor routing. Refer to Industrial Automation Wiring and Grounding Guidelines, publication [1770-4.1](#).

Environmental Specifications

Attribute	1734-OE2C	1734-OE2V
Operational Temperature	IEC 60068-2-1 (Test Ad, Operating Cold), IEC 60068-2-2 (Test Bd, Operating Dry Heat), IEC 60068-2-14 (Test Nb, Operating Thermal Shock): -20...55 °C (-4...131 °F)	
Temperature, surrounding air, max	55 °C (131 °F)	
Storage Temperature	IEC 60068-2-1 (Test Ab, Unpackaged Nonoperating Cold), IEC 60068-2-2 (Test Bb, Unpackaged Nonoperating Dry Heat), IEC 60068-2-14 (Test Na, Unpackaged Nonoperating Thermal Shock): -40...85 °C (-40...185 °F)	
Relative Humidity	IEC 60068-2-30 (Test Db, Unpackaged Nonoperating Damp Heat): 5...95% noncondensing	
Vibration	IEC60068-2-6 (Test Fc, Operating) 5 g @ 10...500 Hz	
Shock Operating Non-Operating	IEC 60068-2-27 (Test Ea, Unpackaged Shock) 30 g 50 g	
Emissions	CISPR 11: Group 1, Class A	
ESD Immunity	IEC6100-4-2 6 kV contact discharges 8 kV air discharges	
Radiated RF Immunity	IEC 61000-4-3: 10 V/m with 1kHz sine-wave 80%AM from 30 MHz to 2000 MHz 10 V/m with 200 Hz 50% Pulse 100%AM at 900 MHz 10 V/m with 200 Hz 50% Pulse 100%AM at 1890 MHz	
EFT/B Immunity	IEC 61000-4-4: ±3 kV at 2.5 kHz on signal ports	
Surge Transient Immunity	IEC 61000-4-5: ±2 kV line-earth(CM) on shielded ports	
Conducted RF Immunity	IEC61000-4-6 10 Vrms with 1 kHz sine-wave 80%AM from 150 kHz to 80 MHz	

Certifications

Certification (when product is marked)⁽¹⁾	Value
c-UL-us	UL Listed Industrial Control Equipment, certified for US and Canada. See UL File E65584. UL Listed for Class I, Division 2 Group A,B,C,D Hazardous Locations, certified for U.S. and Canada. See UL File E194810.
CE	European Union 89/336/EEC EMC Directive, compliant with: EN 50082-2; Industrial Immunity EN 61326; Meas./Control/Lab., Industrial Requirements EN 61000-6-2; Industrial Immunity EN 61000-6-4; Industrial Emissions European Union 72/23/EEC LVD Directive, compliant with: EN 61131-2; Programmable Controllers
C-Tick	Australian Radiocommunications Act, compliant with: AS/NZS CISPR 11; Industrial Emissions
Ex 	European Union 94/9/EC ATEX Directive, compliant with: EN60079-15: 2010; Potentially Explosive Atmospheres, Protection "n" EN60079-0:2012+A11: 2013; General Requirements II 3 G Ex nA IIC T4 Gc DEMKO 04 ATEX 0330347X

⁽¹⁾ See the Product Certification link at <http://www.rockwellautomation.com/products/certification/> for Declaration of Conformity, Certificates, and other certification details.

Rockwell Automation Support

Rockwell Automation provides technical information on the Web to assist you in using its products. At <http://www.rockwellautomation.com/support/>, you can find technical manuals, a knowledge base of FAQs, technical and application notes, sample code and links to software service packs, and a MySupport feature that you can customize to make the best use of these tools.

For an additional level of technical phone support for installation, configuration and troubleshooting, we offer TechConnect support programs. For more information, contact your local distributor or Rockwell Automation representative, or visit <http://www.rockwellautomation.com/support/>.

Installation Assistance

If you experience a problem within the first 24 hours of installation, please review the information that's contained in this manual. You can also contact a special Customer Support number for initial help in getting your product up and running.

United States or Canada	1.440.646.3434
Outside United States or Canada	Use the Worldwide Locator at http://www.rockwellautomation.com/support/americas/phone_en.html , or contact your local Rockwell Automation representative.

New Product Satisfaction Return

Rockwell Automation tests all of its products to ensure that they are fully operational when shipped from the manufacturing facility. However, if your product is not functioning and needs to be returned, follow these procedures.

United States	Contact your distributor. You must provide a Customer Support case number (call the phone number above to obtain one) to your distributor to complete the return process.
Outside United States	Please contact your local Rockwell Automation representative for the return procedure.

Documentation Feedback

Your comments will help us serve your documentation needs better. If you have any suggestions on how to improve this document, complete this form, publication [RA-DU002](#), available at <http://www.rockwellautomation.com/literature/>.

Allen-Bradley, Rockwell Automation, POINT I/O, and TechConnect are trademarks of Rockwell Automation, Inc.

Trademarks not belonging to Rockwell Automation are property of their respective companies.

Rockwell Otomasyon Ticaret A.Ş., Kar Plaza İş Merkezi E Blok Kat:6 34752 İçerenköy, İstanbul, Tel: +90 (216) 5698400

www.rockwellautomation.com

Power, Control and Information Solutions Headquarters

Americas: Rockwell Automation, 1201 South Second Street, Milwaukee, WI 53204-2496 USA, Tel: (1) 414.382.2000, Fax: (1) 414.382.4444
Europe/Middle East/Africa: Rockwell Automation, Voorlaan/Boulevard du Souverain 36, 1170 Brussels, Belgium, Tel: (32) 2 663 0600, Fax: (32) 2 663 0640
Asia Pacific: Rockwell Automation, Level 14, Core F, Cyberport 3, 100 Cyberport Road, Hong Kong, Tel: (852) 2887 4788, Fax: (852) 2508 1846

Publication 1734-IN002D-EN-E - October 2015

Supersedes Publication 1734-IN002C-EN-E - April 2005

Copyright © 2015 Rockwell Automation, Inc. All rights reserved.