

# FILTRI ANTIDISTURBO

TRANSIENT VOLTAGE SUPPRESSORS

**L'**apertura e la chiusura dei comandi di una qualsiasi apparecchiatura elettrica provocano determinati fenomeni in funzione dei parametri interessati: tipo del carico, dispositivi accoppiati (cavi, schermi, ecc.), comportamento dei contatti degli organi di comando ecc., dove il termine "contatti" può riferirsi sia a quelli elettromeccanici sia a quelli elettronici. Le sovratensioni che si hanno in queste apparecchiature devono venire sopresse da adatti dispositivi. Per dare un'idea di questi fenomeni indichiamo (vedi sotto) 3 diagrammi che riproducono il "noise" generato dalla chiusura di un carico induttivo. Ciascun carico rappresenta, in realtà, una combinazione di fattori come resistenze, carichi capacitivi, induttivi, tipo dell'alimentazione, variazioni termiche ecc., che determinano le particolari condizioni da considerare nella scelta del filtro più appropriato, in grado di evitare le disfunzioni o la stessa distruzione del circuito collegato. La soppressione, la cui efficacia può avere diversi livelli, si ottiene impiegando un modulo inserito in parallelo al carico induttivo. Le funzioni a cui tale modulo deve rispondere sono l'eliminazione dell'aumento di tensione e lo scarico più rapido possibile dell'energia magnetica accumulata. Un altro elemento importante da considerare è che il dispositivo antidisturbo non provochi a sua volta disturbi e non modifichi il funzionamento a regime del circuito collegato. Il posizionamento del modulo antidisturbo è altresì importante da valutare: si consiglia infatti di inserire il gruppo quanto più possibile vicino all'origine del disturbo stesso, anche per evitare di coinvolgere nel fenomeno altri componenti (per esempio i cavi). Nei circuiti a corrente continua è particolarmente adatto l'impiego dei diodi, in quelli a corrente alternata l'uso di combinazioni resistenza-condensatore (RC), mentre i varistori sono efficaci per entrambi i tipi di circuito. Sono stati inoltre sviluppati dalla DETAS dispositivi combinati RC + Varistore per ottenere, a seconda dei casi, il miglior risultato. L'ampia gamma DETAS vi permetterà di individuare il filtro adatto alle Vostre esigenze. Inoltre l'Ufficio Tecnico è a Vostra disposizione per ulteriori, più dettagliate informazioni sull'utilizzo e la corretta scelta dei suoi filtri antidisturbo.

**T**he opening and the closing of every electric device generates various phenomena in function of interested parameters: type of loading, connected gears (cables, screens, etc), behaviour of command devices contacts, both electro-mechanical and electrical. The overvoltages so generated must be suppressed by suitable devices.

To give an idea of these phenomena we want to show three diagrams (see below) reproducing the "noise" generated by a stopping of inductive load. Every load represents, in truth, a combination of factors such as, impedance, capacitive load, inductive load, type of input, thermal variations etc., that determinates the variables we have to consider in the choice of the most suitable transient voltage suppressor, capable to avoid malfunctions or directly the destruction of the connected device.

The suppression, that can operate at different levels, is obtained using a module, mounted in parallel to the inductive load. This module must carry out two function: the elimination of the voltage increase and the fastest discharge of the accumulated magnetic energy. Another important element we have to consider is that the suppressor device itself have not to generate noise or modify in any way the normal functionality of the circuit connected to it. The positioning of the suppressor module is another important factor we have to take into account. In fact the best solution would be to mount the suppressor as near as possible to the source of the noise itself, to avoid the involving of other devices in the phenomenon (cables for example).

The use of diodes is suitable in particular for the dumping current circuits, the use of a combinations resistor-capacitor (RC) for alternating current, while varistors are effective in both the types of circuit. In addition of this DETAS has developed combined devices RC + Varistors in order to reach the best results according to different cases. The wide choice available by DETAS will certainly permit you to find the type of suppressor suitable in your application. Finally DETAS Technical Department is at your disposal for further and more detailed information about the most correct use and effective employ of its transient voltage suppressors.

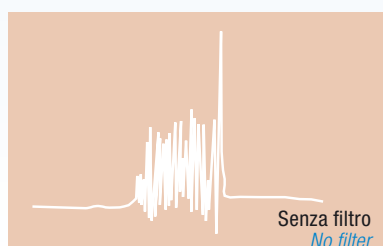

# FILTRI ANTIDISTURBO

Per motori, elettrovalvole, contattori e universali

TRANSIENT VOLTAGE SUPPRESSORS  
For motors, valves adaptors, contactors  
and general purpose

TRANSIENT SUPPRESSORS FILTRI ANTIDISTURBO



02-2009-SOVER L.0

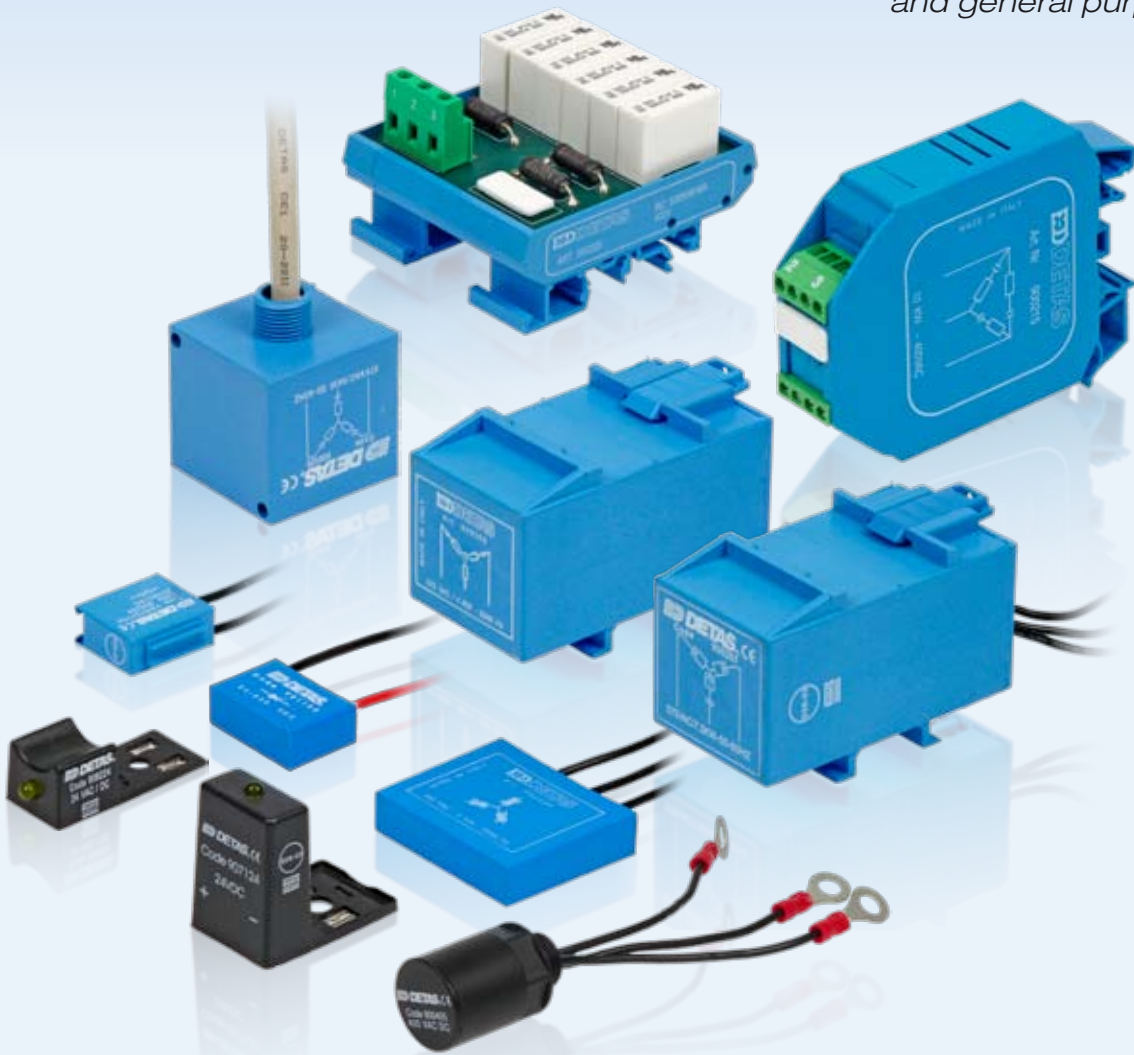

### Trifase per motori For threephase motors

### Monofase universali General purpose

Modello Model	PA	CL	CU	MC	STF	STM	MA	UNI
Custodia Housing								
Potenza motore Motor power range	4 KW	4 KW	4...30 KW	4...10 KW	4...120 KW	4...135 KW	7,5...45 KW	-
V <sub>in</sub> AC [V]	3x400 3x500 3x575	3x400 3x500 3x575	3x400 3x500 3x575	3x400 3x575	3x400 3x500 3x575	3x400 3x500 3x575	3x400 3x500 3x575	24-230 DC 24 AC/DC 110...400 AC
Tipologia Type								

**PA**

trifase per motori  
for threephase motors

Grazie alle dimensioni ridotte, questo filtro motore può essere montato all'interno della morsettiere del motore permettendo di eliminare nel migliore dei modi i picchi di tensione alla disinserzione/inserzione che possono risultare fatali per l'elettronica. La versione consigliata è quella con gruppo RC ma è disponibile anche un modello a varistori. Ideale per motori asincroni trifase 50÷60 Hz con potenze fino a 4 kW, va impiegato dove non avvengano più di un'operazione al secondo. Viene fornito con biadesivo e con cavetti con capocorda di lunghezza 300 mm.

*Thanks to the small dimensions, this filter can be mounted into the motor switchgear allowing to eliminate the voltage peaks at the source. It represents an optimal choice for threephase 50÷60 Hz motors with power up to 4kW. The use of this filter isn't allowed when is required more than one operation in a second. It is supplied with biadhesive and connecting leadwire.*

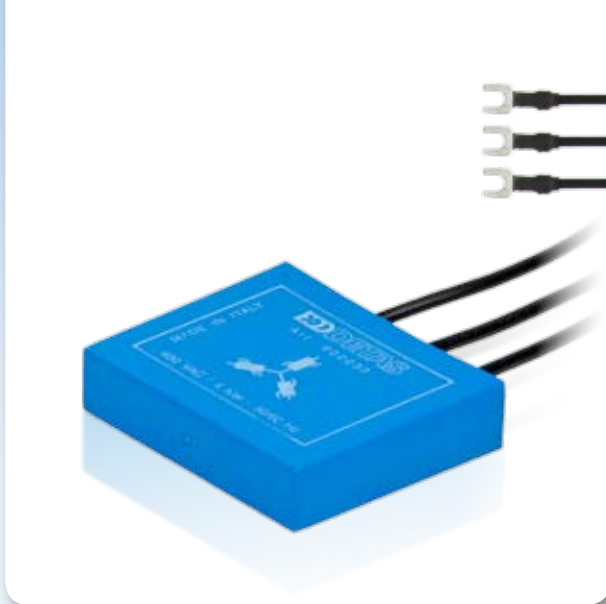

CE

**Specifiche tecniche**  
Specifications

Frequenza motore - <i>Motor frequency</i>	50÷60 Hz (RC); 10÷400 kHz (VDR)
Potenza massima motore - <i>Max. motor power</i>	Fino a 4 kW - <i>Up to 4kW</i>
Massimo numero di manovre - <i>Max. n° cycles</i>	1/sec
Temperatura d'esercizio - <i>Temperature rating</i>	-25°...+85 °C
Custodia - <i>Housing</i>	PBT, UL94-V0
Riempitivo - <i>Potting material</i>	Resina epossidica, UL94-V0 - <i>Epoxy resin, UL94-V0</i>
Grado di protezione - <i>Enclosure protection</i>	IP65 secondo EN 60529 - <i>IP65 according to EN 60529</i>
Allacciamento - <i>Connections</i>	Cavetto 0,75 mm <sup>2</sup> con capocorda (Y) (UL, PVC), L≈300 mm <i>Connecting leadwire 0,75 mm<sup>2</sup> (UL, PVC); L≈300 mm with Y terminals</i>
Montaggio - <i>Mounting</i>	Collegamento in parallelo ai contatti da proteggere o in parallelo al carico induttivo. <i>Mounted in parallel with the contacts to be protected or in parallel with the inductive load.</i>

**Come ordinare**  
How to order

Modello <i>Model</i>	Codice prodotto <i>Code</i>	Tensione AC [V] <i>Rated voltage AC [V]</i>	Potenza max. motore [kW] <i>Max. motor power [kW]</i>	Circuito antidisturbo <i>Device type</i>
VDR 3/4 KW-PA 400V	900030	3x400	4	Varistori a stella - <i>Varistors wye connected</i>
VDR 3/4 KW-PA 500V	900040	3x500	4	Varistori a stella - <i>Varistors wye connected</i>
RC 3/4 KW-CS-PA 575 V	900047	3x575	4	RC a stella - <i>RC wye connected</i>
RC 3/4 KW-PA 575V	900050	3x575	4	RC a stella - <i>RC wye connected</i>

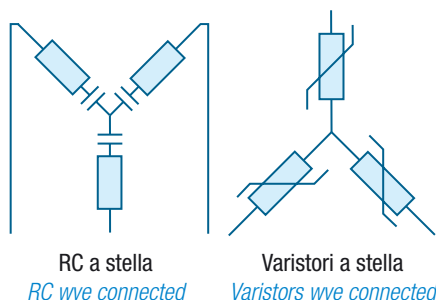
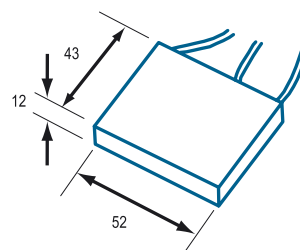
**Schema elettrico**  
*Electric schematic*

**Dimensioni [mm]**  
*Dimensions [mm]*

**CL**trifase per motori  
for threephase motors

CE

La forma cilindrica filettata (PG9) permette di avvitare questo filtro direttamente all'uscita cavi della morsettiera del motore. E' disponibile la versione a varistori per tensioni trifase di 400 e 500 Vac.

*The threaded (PG9) cylindrical shape allows to screw this filter directly on output cables of the motor switchgear. It is available in varistors version with threephase 400 and 500 Vac.*

### Specifiche tecniche

Specifications

Frequenza motore - <i>Motor frequency</i>	10÷400 kHz
Potenza massima motore - <i>Max. motor power</i>	Fino a 4 kW - <i>Up to 4kW</i>
Massimo numero di manovre - <i>Max. n° cycles</i>	1/sec
Temperatura d'esercizio - <i>Temperature rating</i>	-25°...+85 °C
Custodia - <i>Housing</i>	ABS, UL94-V0
Riempitivo - <i>Potting material</i>	Resina epossidica, UL94-V0 - <i>Epoxy resin, UL94-V0</i>
Grado di protezione - <i>Enclosure protection</i>	IP65 secondo EN 60529 - <i>IP65 according to EN 60529</i>
Allacciamento - <i>Connections</i>	Cavetto 0,75 mm <sup>2</sup> con capocorda ad occhiello diametro 4mm (UL, PVC), L≈150 mm <i>Connecting leadwire 0,75 mm<sup>2</sup> (UL, PVC), L≈150 mm with 4mm diameter run terminals.</i>
Montaggio - <i>Mounting</i>	Collegamento in parallelo ai contatti da proteggere o in parallelo al carico induttivo. <i>Mounted in parallel with the contacts to be protected or in parallel with the inductive load.</i>

### Come ordinare

How to order

Modello <i>Model</i>	Codice prodotto <i>Code</i>	Tensione AC [V] <i>Rated voltage AC [V]</i>	Potenza max. motore [kW] <i>Max. motor power [kW]</i>	Circuito antidisturbo <i>Device type</i>
VDR 3/4 KW-CL 400V	900405	3x400	4	Varistori a stella - <i>Varistors wye connected</i>
VDR 3/4 KW-CL 500V	900406	3x500	4	Varistori a stella - <i>Varistors wye connected</i>

### Schema elettrico

Electric schematic

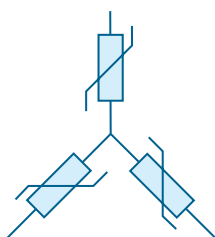

Varistori a stella  
*Varistors wye connected*

### Dimensioni [mm]

Dimensions [mm]

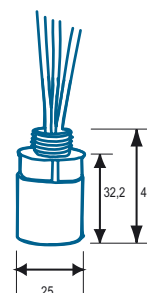

**CU**

trifase per motori  
for threephase motors

Questo filtro con contenitore cubico è disponibile in diverse versioni che si differenziano per il diverso circuito antidisturbo utilizzato, in particolare è disponibile un modello con combinazione RC+varistore certamente il più performante sotto l'aspetto della soppressione del disturbo. Il filtro va avvitato sull'entrata cavi della morsetteria del motore oppure può essere montato con delle fascette all'esterno della stessa. Viene fornito con un cavo tripolare da allacciare in parallelo ai morsetti del motore.

*This filter is proposed in a "cube" box and several different models available depending on the type of suppressor device used, in particular the RC+varistor combination offers high level of suppression. The filter can be screwed on the entrance of motor switchgear or can be mounted outside.*

**Specifiche tecniche**  
Specifications

Frequenza motore - <i>Motor frequency</i>	50÷60 Hz (RC); 10÷400 kHz (VDR)
Potenza massima motore - <i>Max. motor power</i>	Da 4 kW a 30kW - <i>From 4kW to 30 kW</i>
Massimo numero di manovre - <i>Max. n° cycles</i>	1/sec
Temperatura d'esercizio - <i>Temperature rating</i>	-25°...+85 °C
Custodia - <i>Housing</i>	Polycarbonato classe V2 - <i>Polycarbonate V2 class</i>
Riempitivo - <i>Potting material</i>	Resina epossidica, UL94-V0 - <i>Epoxy resin, UL94-V0</i>
Grado di protezione - <i>Enclosure protection</i>	IP65 secondo EN 60529 - <i>IP65 according to EN 60529</i>
Allacciamento - <i>Connections</i>	Cavetto 3x1 mm <sup>2</sup> (UL 94-V0, PVC), L≈300 mm; filetto PG9 <i>Connecting leadwire 3x1 mm<sup>2</sup> (UL94-V0, PVC); L≈300 mm; thread PG9</i>
Montaggio - <i>Mounting</i>	Collegamento in parallelo ai contatti da proteggere o in parallelo al carico induttivo. <i>Mounted in parallel with the contacts to be protected or in parallel with the inductive load.</i>

**Come ordinare**  
How to order

Modello <i>Model</i>	Codice prodotto <i>Code</i>	Tensione AC [V] <i>Rated voltage AC [V]</i>	Potenza max. motore [kW] <i>Max. motor power [kW]</i>	Circuito antidisturbo <i>Device type</i>
VDR 3/4 KW-CU 400V	900142	3x400	4	Varistori a stella - <i>Varistors wye connected</i>
VDR 3/4 KW-CU 500V	900147	3x500	4	Varistori a stella - <i>Varistors wye connected</i>
RC 3/4 KW-CU 575V	900120	3x575	4	RC a stella - <i>RC wye connected</i>
RC 3/7,5 KW-CU 575V	900127	3x575	7,5	RC a stella - <i>RC wye connected</i>
VDR 3/10 KW-CU 400V	900140	3x400	10	Varistori a stella - <i>Varistors wye connected</i>
VDR 3/10 KW-CU 500V	900145	3x500	10	Varistori a stella - <i>Varistors wye connected</i>
RC 3/10 KW-CU 400V	900125	3x400	10	RC a triangolo - <i>RC delta connected</i>
RC+VDR 3/10 KW-CU 400V	900130	3x400	10	RC//Varistori a stella - <i>RC//Varistors wye connected</i>
RC+VDR 3/10 KW-CU 500V	900135	3x500	10	RC//Varistori a stella - <i>RC//Varistors wye connected</i>
VDR 3/20 KW-CU 400V	900155	3x400	20	Varistori a stella - <i>Varistors wye connected</i>
VDR 3/20 KW-CU 500V	900160	3x500	20	Varistori a stella - <i>Varistors wye connected</i>
RC+VDR 3/20 KW-CU 400V	900170	3x400	20	RC//Varistori a stella - <i>RC//Varistors wye connected</i>
RC+VDR 3/20 KW-CU 500V	900180	3x500	20	RC//Varistori a stella - <i>RC//Varistors wye connected</i>
VDR 3/30 KW-CU 400V	900185	3x400	30	Varistori a stella - <i>Varistors wye connected</i>
VDR 3/30 KW-CU 500V	900190	3x500	30	Varistori a stella - <i>Varistors wye connected</i>

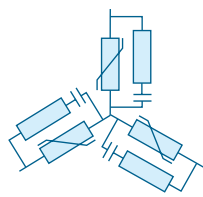
**Schema elettrico**  
*Electric schematic*

RC//Varistori a stella  
*RC//Varistors wye connected*

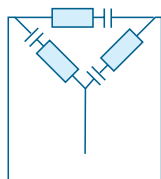

RC a triangolo  
*RC delta connected*

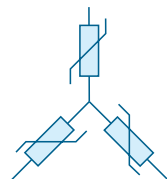

Varistori a stella  
*Varistors wye connected*

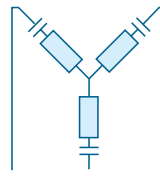

RC a stella  
*RC wye connected*

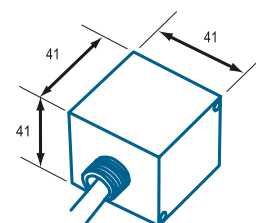
**Dimensioni [mm]**  
*Dimensions [mm]*

**MC**trifase per motori  
for threephase motors

CE

Questo filtro antidisturbo viene montato su barra DIN con allacciamento a morsetti. Lo spessore contenuto (22,5 mm) permette un notevole risparmio di spazio. Il filtro può inoltre essere identificato. Disponibile solo in versione RC con potenza massima del motore pari a 10 kW.

*This filter is prepared for DIN rail mounting and supplied of screw terminals. Thanks to its small thickness (only 22,5 mm) this filter allows to save space. This filter is only available in RC version and up to 10 kW motor power.*

### Specifiche tecniche

Specifications

Frequenza motore - <i>Motor frequency</i>	50 ÷ 60 Hz
Potenza massima motore - <i>Max. motor power</i>	Fino a 10 kW - <i>Up to 10 kW</i>
Massimo numero di manovre - <i>Max. n° cycles</i>	1/sec.
Temperatura d'esercizio - <i>Temperature rating</i>	-25°...+85 °C
Custodia - <i>Housing</i>	Polycarbonato classe V2 - <i>Polycarbonate V2 class</i>
Allacciamento - <i>Connections</i>	Morsetti a vite - <i>Screw terminals</i>
Montaggio - <i>Mounting</i>	Collegamento in parallelo ai contatti da proteggere o in parallelo al carico induttivo <i>Mounted in parallel with the contacts to be protected or in parallel with the inductive load</i>

### Come ordinare

How to order

Modello <i>Model</i>	Codice prodotto <i>Code</i>	Tensione AC [V] <i>Rated voltage AC [V]</i>	Potenza max. motore [kW] <i>Max. motor power [kW]</i>	Circuito antidisturbo <i>Device type</i>
RC 3/4 KW-MC 575V	900200	3x575	4	RC a stella - <i>RC wye connected</i>
RC 3/7,5 KW-MC 575V	900210	3x575	7,5	RC a stella - <i>RC wye connected</i>
RC 3/10 KW-MC 400V	900215	3x400	10	RC a triangolo - <i>RC delta connected</i>

### Schema elettrico

Electric schematic

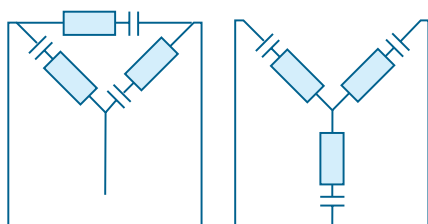

RC a triangolo  
*RC delta connected*

RC a stella  
*RC wye connected*

### Dimensioni [mm]

Dimensions [mm]

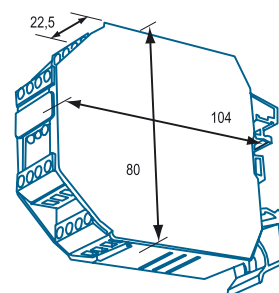

TRANSIENT SUPPRESSORS FILTRI ANTIDISTURBO

# STF

trifase per motori  
for threephase motors

Questo filtro per motore viene montato direttamente su barra DIN. Sopra il filtro può poi essere montato il contattore di comando. Disponibile in 2 diverse larghezze (45 e 54 mm), è disponibile per motori aventi potenza massima di 120 kW. Sono disponibili diversi modelli sia con varistori che in versione combinata RC + Varistori. È anche possibile ordinare la stessa versione ma con allacciamento a morsetti (STM).

*This motor filter can be mounted directly on DIN rail.  
Moreover the contactor can be placed upon it for a more easy parallel connection of the three cables. Available in two different widths (45 and 54 millimeters), can be used for motors up to 120 kW power. Several models are available with varistors, RC or combined version RC+Varistors. It is also possible to order the same version but with screw terminals (STM).*

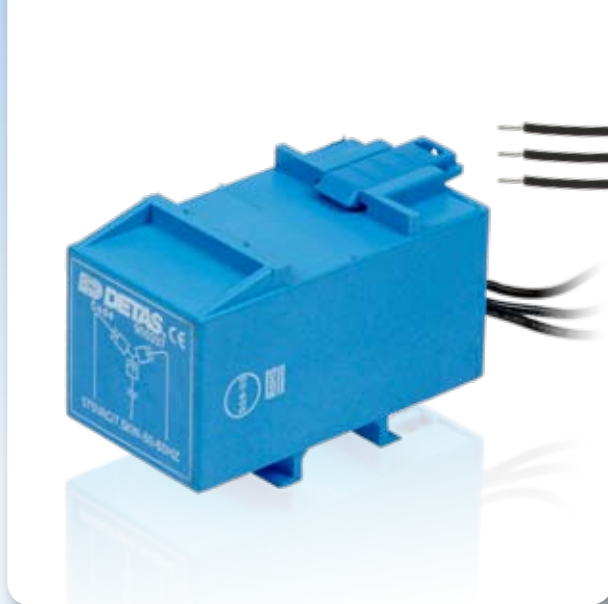

CE

### Specifiche tecniche Specifications

Frequenza motore - <i>Motor frequency</i>	50÷60 Hz (RC); 10÷400 kHz (VDR)
Potenza massima motore - <i>Max. motor power</i>	Fino a 120 kW - <i>Up to 120 kW</i>
Massimo numero di manovre - <i>Max. n° cycles</i>	1/sec.
Temperatura d'esercizio - <i>Temperature rating</i>	-25°...+85 °C
Custodia - <i>Housing</i>	Policarbonato classe V2 - <i>Polycarbonate V2 class</i>
Riempitivo - <i>Potting material</i>	Resina epossidica, UL94-V0 - <i>Epoxy resin, UL94-V0</i>
Allacciamento - <i>Connections</i>	Cavetto 0,75 mm <sup>2</sup> fino a 10 kW, 1,5 mm <sup>2</sup> oltre i 10 kW (UL, PVC), L≈150 mm <i>Connecting leadwire 0,75 mm<sup>2</sup> up to 10 kW, 1,5 mm<sup>2</sup> over 10 kW (UL, PVC), L≈300 mm</i>
Montaggio - <i>Mounting</i>	Collegamento in parallelo ai contatti da proteggere o in parallelo al carico induttivo <i>Mounted in parallel with the contacts to be protected or in parallel with the inductive load</i>

### Schema elettrico Electric schematic

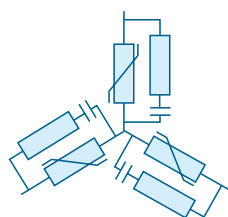

RC/Varistori a stella  
*RC/Varistors wye connected*

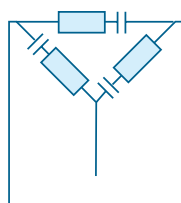

RC a triangolo  
*RC delta connected*

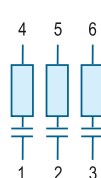

RC singoli  
*RC*

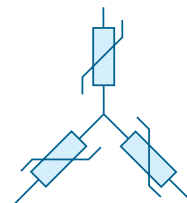

Varistori a stella  
*Varistors wye connected*

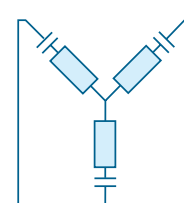

RC a stella  
*RC wye connected*

**Come ordinare**  
How to order

Modello <i>Model</i>	Codice prodotto <i>Code</i>	Tensione AC [V] <i>Rated voltage AC [V]</i>	Potenza max. motore [kW] <i>Max. motor power [kW]</i>	Circuito antidisturbo <i>Device type</i>
RC 3/4 KW-STF 575V	900304	3x575	4	RC a stella - <i>RC wye connected</i>
RC 3/7,5 KW-STF 575V	900307	3x575	7,5	RC a stella - <i>RC wye connected</i>
RC 3/10 KW-STF 400V	900310	3x400	10	RC a triangolo - <i>RC delta connected</i>
VDR 3/10 KW-STF 500V	900314	3x500	10	Varistori a stella - <i>Varistors wye connected</i>
VDR 3/10 KW-STF 400V	900316	3x400	10	Varistori a stella - <i>Varistors wye connected</i>
RC 3/10 KW-ST6F 400/575V	900319	3x400/575	10	RC singolo - <i>RC</i>
RC 3/20 KW-ST6F 400/575V	900320	3x400/575	20	RC singolo - <i>RC</i>
RC+VDR 3/20 KW-STF 500V	900324	3x500	20	RC//Varistori a stella - <i>RC//Varistors wye connected</i>
RC 3/20 KW-STF 575V	900325	3x575	20	RC a stella - <i>RC wye connected</i>
VDR 3/30 KW-STF 500V	900330	3x500	30	Varistori a stella - <i>Varistors wye connected</i>
VDR 3/30 KW-STF 400V	900332	3x400	30	Varistori a stella - <i>Varistors wye connected</i>
RC+VDR 3/30 KW-STF 500V	900335	3x500	30	RC//Varistori a stella - <i>RC//Varistors wye connected</i>
RC+VDR 3/30 KW-STF 400V	900336	3x400	30	RC//Varistori a stella - <i>RC//Varistors wye connected</i>
RC+VDR 3/1/4 KW-STF 400/24V	900345	3x400	4	RC//Varistori singoli - <i>RC//Varistors</i>
RC+VDR 3/1/4 KW-STF 400/110V	900350	3x400	4	RC//Varistori singoli - <i>RC//Varistors</i>
RC+VDR 3/30 KW-ST6F 500V	900365	3x500	30	RC//Varistori singoli - <i>RC//Varistors</i>
VDR 3/75 KW-STF 500V	900374	3x500	75	Varistori a stella - <i>Varistors wye connected</i>
VDR 3/75 KW-STF 400V	900376	3x400	75	Varistori a stella - <i>Varistors wye connected</i>
VDR 3/75 KW-STF 400V	900390	3x400	75	Varistori singoli - <i>Varistors</i>
RC+VDR 3/120 KW-ST6F 500V	900395	3x500	120	RC//Varistori singoli - <i>RC//Varistors</i>
RC+VDR 3/120 KW-ST6F 400V	900396	3x400	120	RC//Varistori singoli - <i>RC//Varistors</i>

**Schema elettrico**  
*Electric schematic*

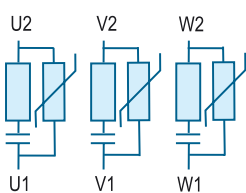

RC//Varistori singoli  
*RC//Varistors*

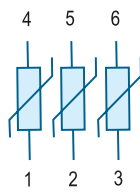

Varistori singoli  
*Varistors*

**Dimensioni [mm]**  
*Dimensions [mm]*

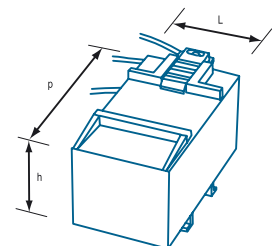

L=45; h=54; p=83 (≤10kW)  
L=54; h=54; p=83 (>10kW)

**STM**

trifase per motori  
for threephase motors

Questo filtro per motore viene montato direttamente su barra DIN. Sopra il filtro può poi essere montato il contattore di comando. Disponibile in 2 diverse larghezze (45 e 54 mm), è disponibile per motori aventi potenza massima di 135 kW. Sono disponibili diversi modelli sia con Varistori che in versione combinata RC + Varistori. È anche possibile ordinare la stessa versione ma con collegamento a cavetti (STF).

*This motor filter can be mounted directly on DIN rail.  
Moreover the contactor can be placed upon it for a more easy parallel connection of the three cables. Available in two different widths (45 and 54 millimeters), can be used for motors up to 135 kW power. Several models are available with varistors, RC or combined version RC + Varistors. It is also possible to order the same version but with connection cables (STF).*



CE

**Specifiche tecniche**  
Specifications

Frequenza motore - <i>Motor frequency</i>	50÷60 Hz (RC); 10÷400 kHz (VDR)
Potenza massima motore - <i>Max. motor power</i>	Fino a 135 kW - <i>Up to 135 kW</i>
Massimo numero di manovre - <i>Max. n° cycles</i>	1/sec.
Temperatura d'esercizio - <i>Temperature rating</i>	-25°...+85 °C
Custodia - <i>Housing</i>	Policarbonato classe V2 - <i>Polycarbonate V2 class</i>
Riempitivo - <i>Potting material</i>	Resina epossidica, UL94-V0 - <i>Epoxy resin, UL94-V0</i>
Allacciamento - <i>Connections</i>	Morsetti a vite - <i>Screw terminals</i>
Montaggio - <i>Mounting</i>	Collegamento in parallelo ai contatti da proteggere o in parallelo al carico induttivo <i>Mounted in parallel with the contacts to be protected or in parallel with the inductive load</i>

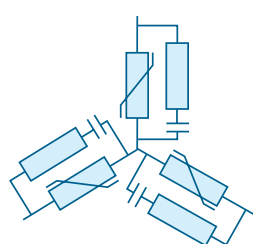
**Schema elettrico**  
Electric schematic

RC/Varistori a stella  
*RC/Varistors wye connected*

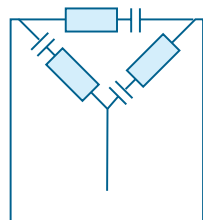

RC a triangolo  
*RC delta connected*

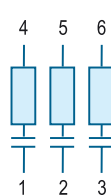

RC singoli  
*RC*

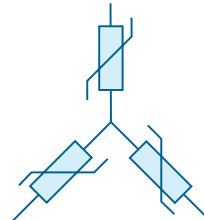

Varistori a stella  
*Varistors wye connected*

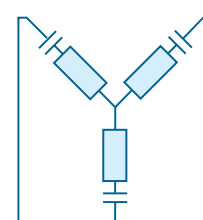

RC a stella  
*RC wye connected*

**Come ordinare**  
How to order

Modello Model	Codice prodotto Code	Tensione AC [V] Rated voltage AC [V]	Potenza max. motore [kW] Max. motor power [kW]	Circuito antidisturbo Device type
RC 3/4 KW-STM 575V	900305	3x575	4	RC a stella - RC wye connected
RC 3/7,5 KW-STM 575V	900308	3x575	7,5	RC a stella - RC wye connected
RC 3/10 KW-STM 400V	900312	3x400	10	RC a triangolo - RC delta connected
VDR 3/10 KW-STM 500V	900315	3x500	10	Varistori a stella - Varistors wye connected
RC 3/20 KW-ST6M 400/575V	900321	3x400/575	20	RC singolo - RC
RC+VDR 3/20 KW-STM 500V	900327	3x500	20	RC//Varistori a stella - RC//Varistors wye connected
RC 3/20 KW-STM 575V	900328	3x575	20	RC a stella - RC wye connected
VDR 3/30 KW-STM 500V	900331	3x500	30	Varistori a stella - Varistors wye connected
VDR 3/30 KW-STM 400V	900333	3x400	30	Varistori a stella - Varistors wye connected
RC+VDR 3/30 KW-STM 500V	900337	3x500	30	RC//Varistori a stella - RC//Varistors wye connected
RC+VDR 3/30 KW-ST6M 400V	900364	3x400	30	RC//Varistori singoli - RC//Varistors
RC+VDR 3/30 KW-ST6M 500V	900367	3x500	30	RC//Varistori singoli - RC//Varistors
VDR 3/75 KW-STM 500V	900378	3x500	75	Varistori a stella - Varistors wye connected
RC+VDR 3/120 KW-STM 400V	900380	3x400	120	RC//Varistori a stella - RC//Varistors wye connected
VDR 3/75 KW-ST6M 500V	900391	3x500	75	Varistori singoli - Varistors
RC+VDR 3/120 KW-ST6M 500V	900393	3x500	120	RC//Varistori singoli - RC//Varistors
RC+VDR 3/120 KW-ST6M 400V	900394	3x400	120	RC//Varistori singoli - RC//Varistors
RC+VDR 3/135 KW-ST6M 400V	900397	3x400	135	RC//Varistori singoli - RC//Varistors
RC+VDR 3/120 KW-ST6M 500V	900398	3x500	135	RC//Varistori singoli - RC//Varistors



02-2009-SDV-ER 1.0

**Schema elettrico**  
Electric schematic

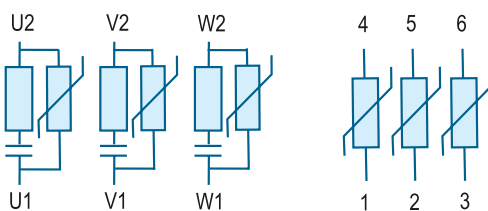

RC//Varistori singoli  
RC//Varistors

Varistori singoli  
Varistors

**Dimensioni [mm]**  
Dimensions [mm]

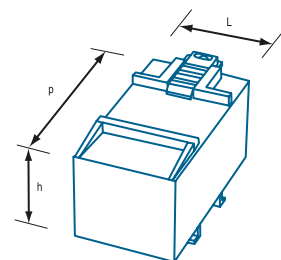

L=45; h=54; p=83 (≤10kW)  
L=54; h=54; p=83 (>10kW)

**MA**

trifase per motori  
for threephase motors

Trattasi di un filtro in versione "aperta" agganciabile su guida DIN e disponibile per motori trifase fino ad un massimo di 45 kW. È disponibile solo in versione RC. Anche in questa versione vengono utilizzati condensatori in poliestere ad armatura metallizzata di elevata qualità.

*This "open" version filter is prepared for DIN rail mounting and can be used in threephase motors up to a maximum power of 45kW. It is available only in RC version. Also this version uses high quality no-inductive metallized film polypropylene capacitors.*



CE

**Specifiche tecniche**  
Specifications

Frequenza motore - <i>Motor frequency</i>	50 ÷ 60 Hz
Potenza massima motore - <i>Max. motor power</i>	Fino a 45 kW - <i>Up to 45 kW</i>
Massimo numero di manovre - <i>Max. n° cycles</i>	1/sec.
Temperatura d'esercizio - <i>Temperature rating</i>	-25°...+85 °C
Custodia - <i>Housing</i>	Policarbonato classe V2 - <i>Polycarbonate V2 class</i>
Allacciamento - <i>Connections</i>	Morsetti a vite - <i>Screw terminals</i>
Montaggio - <i>Mounting</i>	Collegamento in parallelo ai contatti da proteggere o in parallelo al carico induttivo <i>Mounted in parallel with the contacts to be protected or in parallel with the inductive load</i>

**Come ordinare**  
How to order

Modello <i>Model</i>	Codice prodotto <i>Code</i>	Tensione AC [V] <i>Rated voltage AC [V]</i>	Potenza max. motore [kW] <i>Max. motor power [kW]</i>	Circuito antidisturbo <i>Device type</i>	Dimensioni <i>Dimensions [mm]</i>		
					L	h	p
RC 3/7,5 KW-MA 575V	900216	3x575	7,5	RC a stella - <i>RC wye connected</i>	57	46	80
RC 3/10 KW-MA 400V	900218	3x400	10	RC a triangolo - <i>RC delta connected</i>	57	46	80
RC 3/20 KW-MA 400V	900220	3x400	20	RC a triangolo - <i>RC delta connected</i>	68	46	80
RC 3/30 KW-MA 400/575V	900230	3x400/575	30	RC singoli - <i>RC</i>	90	46	80
RC 3/45 KW-MA 400/575V	900245	3x400/575	45	RC singoli - <i>RC</i>	100	46	80

**Schema elettrico**  
*Electric schematic*

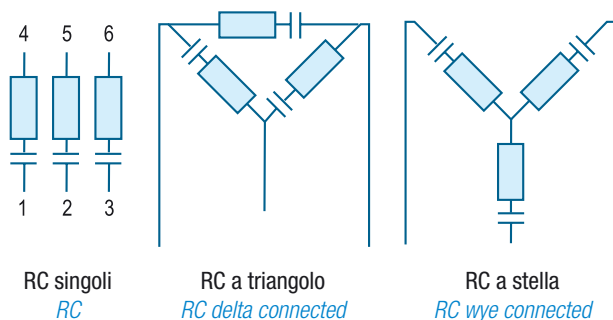

**Dimensioni**  
*Dimensions*

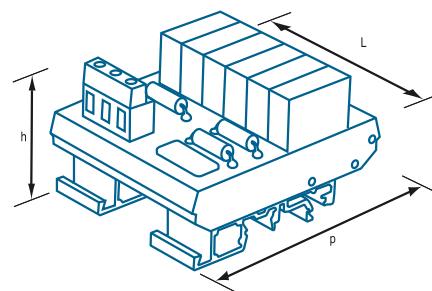

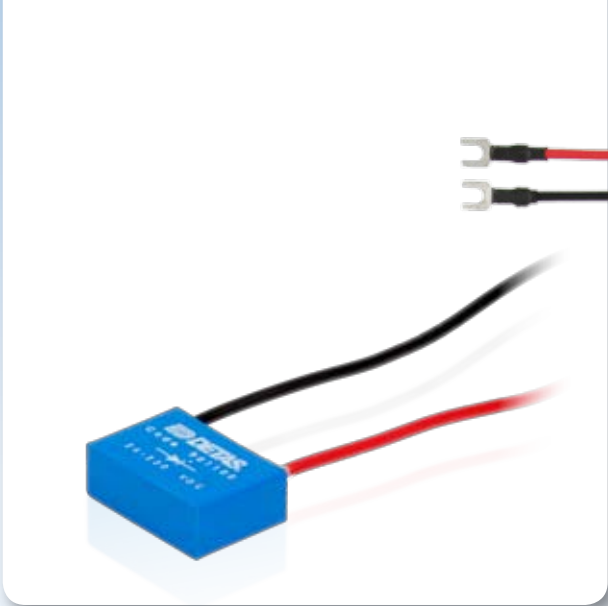

Questo antidisturbo "universale" per tensioni monofase, presenta un contenitore dalle dimensioni molto compatte, che può essere posizionato in canalina oppure attaccato al dispositivo da filtrare tramite biadesivo. Di particolare interesse la serie RC + Varistore che rende possibile l'utilizzo del filtro senza preoccuparsi di dimensionare lo stesso a seconda del carico interessato. Sarà infatti sufficiente scegliere la tensione di funzionamento e il circuito RC + Varistore penserà a filtrare nel modo migliore.

*This general purpose filter with single phase input is proposed in a very compact size. It can be mounted as desired or attacked directly on the device through biadhesive. The RC + Varistor is a particularly interesting model because it allows to use the filter without considering the load. In fact it is enough to choose the operation voltage and the circuit RC +Varistor will do the suppressing action in the better way.*

### Specifiche tecniche Specifications

Temperatura d'esercizio - <i>Temperature rating</i>	-25°...+85 °C
Custodia - <i>Housing</i>	PBT, UL94-V0
Riempitivo - <i>Potting material</i>	Resina epossidica, UL94-V0 - <i>Epoxy resin, UL94-V0</i>
Allacciamento - <i>Connections</i>	Cavetto 0,75 mm <sup>2</sup> con capocorda (Y) (UL, PVC), L≈200 mm <i>Connecting leadwire 0,75 mm<sup>2</sup> (UL, PVC); L≈200 mm with Y terminals</i>
Montaggio - <i>Mounting</i>	Collegamento in parallelo ai contatti da proteggere o in parallelo al carico induttivo <i>Mounted in parallel with the contacts to be protected or in parallel with the inductive load</i>

### Come ordinare How to order

Modello <i>Model</i>	Codice prodotto <i>Code</i>	Tensione [V] <i>Rated voltage [V]</i>	Circuito antidisturbo <i>Device type</i>
D1A 24-230 VDC	901100	24-230 DC	Diodo 1A - <i>Diode 1A</i>
D3A 24-230 VDC	901103	24-230 DC	Diodo 3A - <i>Diode 3A</i>
VDR 24V	901130	24 AC/DC	Varistore - <i>Varistor</i>
VDR 110V	901135	110 AC	Varistore - <i>Varistor</i>
VDR 230V	901140	230 AC	Varistore - <i>Varistor</i>
VDR 400V	901145	400 AC	Varistore - <i>Varistor</i>
RC 022/100 400V	901160	400 AC	RC - <i>RC</i>
RC 047/25 400V	901165	400 AC	RC - <i>RC</i>
RC 047/220 400V	901170	400 AC	RC - <i>RC</i>
RC 022/25 400V	901175	400 AC	RC - <i>RC</i>
RC 047/100 400V	901176	400 AC	RC - <i>RC</i>
RC 010/220 400V	901177	400 AC	RC//Varistore - <i>RC//Varistor</i>
RC + VDR 047/47 24V	901190	24 AC/DC	RC//Varistore - <i>RC//Varistor</i>
RC + VDR 047/47 110V	901191	110 AC	RC//Varistore - <i>RC//Varistor</i>
RC + VDR 047/47 220V	901192	250 AC	RC//Varistore - <i>RC//Varistor</i>
RC + VDR 047/47 400V	901193	400 AC	RC//Varistore - <i>RC//Varistor</i>
RC 047/110 250V NFNA	901197	250 AC	RC - <i>RC</i>
RC 047/220 400V	901199	400 AC	RC - <i>RC</i>
RC 3.3/68 48V	901210	48 VAC	RC - <i>RC</i>
RC 0.1/100 250V	901215	250 VAC	RC - <i>RC</i>

### Schema elettrico Electric schematic

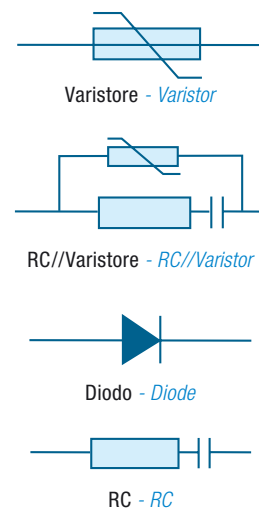

### Dimensioni [mm] Dimensions [mm]

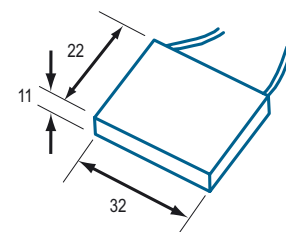

# 18 mm

per elettrovalvole  
valves adaptors

Questo filtro è un adattatore da inserire tra la bobina ed il cappuccio dell'elettrovalvola. Dotato di circuito antidisturbo soppressore risulta inoltre utile in quanto dotato di LED di segnalazione che si illumina quando l'elettrovalvola è eccitata. Questo modello va bene per le valvole sec. DIN 43650 Forma A con distanza contatti di 18 mm.

*This filter is an adapter to be inserted between the coil and the hood of the solenoid. It is equipped with a voltage suppressor circuit and with a status LED. This model is suitable for the solenoid according to 43650 DIN A shape with contacts distance of 18 millimeters.*



CE

### Specifiche tecniche Specifications

Distanza contatti - <i>Contact distance</i>	18 mm
Temperatura d'esercizio - <i>Temperature rating</i>	-25°...+85 °C
Custodia - <i>Housing</i>	Lexan, UL94-V2
Riempitivo - <i>Potting material</i>	Resina epossidica, UL94-V0 - <i>Epoxy resin, UL94-V0</i>
Allacciamento - <i>Connections</i>	Ad innesto tra elettrovalvola e cappuccio - <i>Insertion between coil and hood of the solenoid</i>
LED di segnalazione - <i>Status LED</i>	Colore giallo - <i>Yellow colour</i>
Grado di protezione - <i>Enclosure protection</i>	IP 65 secondo EN 60529 - <i>IP 65 according to EN 60529</i>

### Come ordinare How to order

Modello <i>Model</i>	Codice prodotto <i>Code</i>	Tensione [V] <i>Rated voltage [V]</i>	Circuito antidisturbo <i>Device type</i>
RC + VDR 907 24V	907030	24 AC/DC	RC//Varistore - <i>RC//Varistor</i>
VDR 907 115V	907115	115 AC	Varistore - <i>Varistor</i>
D 907 24V	907124	24 DC	Diodo - <i>Diode</i>
RC + VDR 907 115V	907130	115 AC	RC//Varistore - <i>RC//Varistor</i>
VDR 907 24V	907224	24 AC/DC	Varistore - <i>Varistor</i>
RC + VDR 907 230V	907230	230 AC	RC//Varistore - <i>RC//Varistor</i>
VDR 907 250V	907250	250 AC	Varistore - <i>Varistor</i>

### Schema elettrico Electric schematic



### Dimensioni [mm] Dimensions [mm]

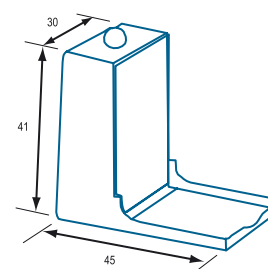

# 11 mm

per elettrovalvole  
valves adaptors



Questo filtro è un adattatore da inserire tra la bobina ed il cappuccio dell'elettrovalvola. Dotato di circuito antidisturbo soppressore risulta inoltre utile in quanto dotato di LED di segnalazione che si illumina quando l'elettrovalvola è eccitata. Questo modello va bene per le valvole sec. DIN 43650 Forma Industriale con distanza contatti di 11 mm.

*This filter can be inserted between the coil and the solenoid's cap. It is equipped with a voltage suppressor circuit and with a status LED. This model is suitable for the solenoid according to 43650 DIN industrial shape with contacts distance of 11 millimeters.*

### Specifiche tecniche Specifications

Distanza contatti - <i>Contact distance</i>	11 mm
Temperatura d'esercizio - <i>Temperature rating</i>	-25°...+85 °C
Custodia - <i>Housing</i>	Lexan, UL94-V2
Riempitivo - <i>Potting material</i>	Resina epossidica, UL94-V0 - <i>Epoxy resin, UL94-V0</i>
Allacciamento - <i>Connections</i>	Ad innesto tra elettrovalvola e cappuccio - <i>Insertion between coil and hood of the solenoid</i>
LED di segnalazione - <i>Status LED</i>	Colore giallo - <i>Yellow colour</i>

### Come ordinare How to order

Modello <i>Model</i>	Codice prodotto <i>Code</i>	Tensione [V] <i>Rated voltage [V]</i>	Tensione di taglio [V] <i>Cut off voltage [V]</i>	Esecuzione <i>Type</i>	Circuito antidisturbo <i>Device type</i>	Dimensioni [mm] <i>Dimensions [mm]</i>		
						L	h	p
VDR 908 24V	908224	24 AC/DC	47 + VNOM	Sinistra - <i>Left</i>	Varistore - <i>Varistor</i>	50	17	21
VDR 909 24V	909224	24 AC/DC	47 + VNOM	Destra - <i>Right</i>	Varistore - <i>Varistor</i>	50	17	21
VDR 910 115V	910115	115 AC	220 + VNOM	Sinistra - <i>Left</i>	Varistore - <i>Varistor</i>	62	17	21
VDR 911 115V	911115	115 AC	220 + VNOM	Destra - <i>Right</i>	Varistore - <i>Varistor</i>	62	17	21
VDR 910 230V	910250	230 AC	470 + VNOM	Sinistra - <i>Left</i>	Varistore - <i>Varistor</i>	62	17	21
VDR 911 230V	911250	230 AC	470 + VNOM	Destra - <i>Right</i>	Varistore - <i>Varistor</i>	62	17	21

### Schema elettrico Electric schematic

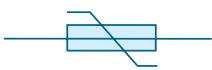

Varistore  
*Varistor*

### Dimensioni Dimensions

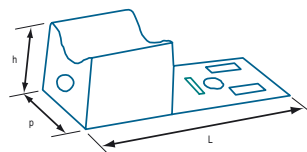

Esecuzione sinistra  
*Left type*

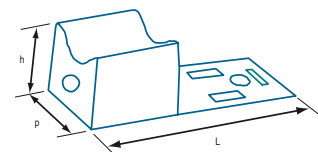

Esecuzione destra  
*Right type*

# Serie 905

per contattori  
for contactors

Questo filtro si adatta al portacartellino di alcuni teleruttori Siemens e K.M. L'etichetta del filtro sarà poi montata sul filtro stesso. Disponibile in varie tensioni di funzionamento, si può ordinare con circuito RC, a varistore o a diodo.

*This filter can be easily adapted to some of the Siemens and Möller contactors. The label of the filter can be placed directly on the filter itself. Available in several working voltage, it can be ordered with RC, varistor or diode circuit.*

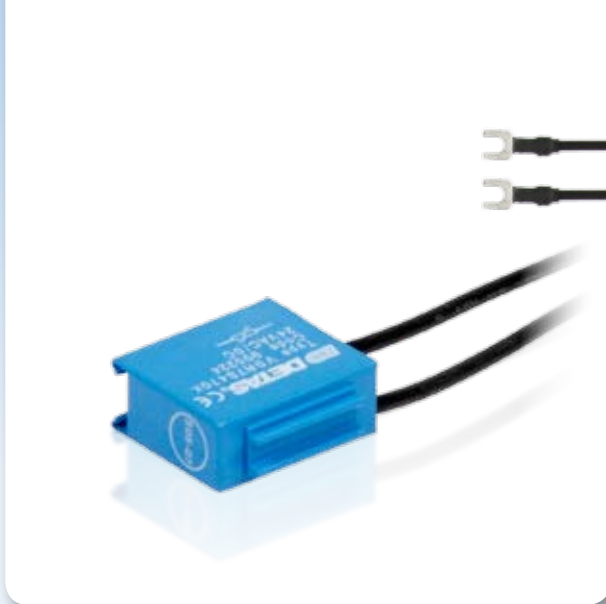

CE

## Specifiche tecniche Specifications

Temperatura d'esercizio - <i>Temperature rating</i>	-25°...+85 °C
Custodia - <i>Housing</i>	Lexan V2 - <i>Polycarbonate V2 class</i>
Riempitivo - <i>Potting material</i>	Resina epossidica, UL94-V0 - <i>Epoxy resin, UL94-V0</i>
Grado di protezione - <i>Enclosure protection</i>	IP65 secondo EN 60529 - <i>IP65 according to EN 60529</i>
Allacciamento - <i>Connections</i>	Cavetto 0,75 mm <sup>2</sup> con capocorda (Y) (UL, PVC), L≈150 mm <i>Connecting leadwire 0,75 mm<sup>2</sup> (UL, PVC); L≈150 mm with Y terminals</i>
Montaggio - <i>Mounting</i>	Collegamento in parallelo ai contatti da proteggere o in parallelo al carico induttivo <i>Mounted in parallel with the contacts to be protected or in parallel with the inductive load</i>

## Come ordinare How to order

Modello <i>Model</i>	Codice prodotto <i>Code</i>	Tensione [V] <i>Rated voltage [V]</i>	Circuito antidisturbo <i>Device type</i>
RCS16/110 24-48V	905048	24-28 AC	Diodo - <i>Diode</i>
DS-1A 24-230VDC	905124	24-230 DC	RC - <i>RC</i>
VDRS-470K 24V	905224	24 AC/DC	Varistore - <i>Varistor</i>
RCS-022/220 250V	905250	110/230 AC	RC - <i>RC</i>

## Schema elettrico Electric schematic

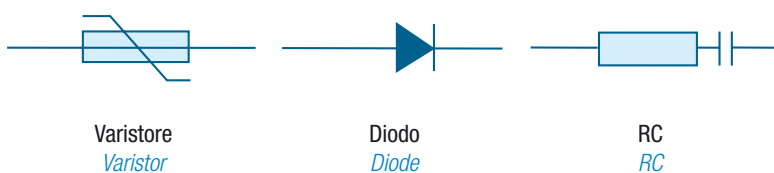

## Dimensioni [mm] Dimensions [mm]

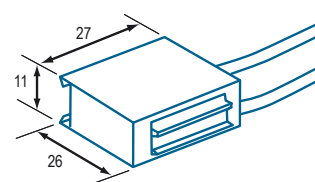

**B**rusche variazioni di corrente nei carichi, collegati alle linee di alimentazione, generano interferenze in radiofrequenza.

Normalmente si definisce disturbo "condotto" l'interferenza che, percorrendo i cavi di alimentazione, si propaga a tutta la rete.

Il disturbo "radiato" viene invece trasmesso via etere dai cavi, che si comportano da antenne.

In realtà la differenza è funzionale alla descrizione del fenomeno in quanto, ad ogni interferenza condotta (tensioni e correnti variabili nel tempo) corrisponde un campo elettromagnetico irradiato. Ogni campo irradiato, d'altra parte induce sui cavi presenti, che si comportano in questo caso da antenne riceventi, un equivalente segnale elettrico condotto (ovviamente l'efficacia di questi fenomeni è dipendente dalla frequenza).

Particolare importanza assume l'impiego di filtri antidisturbo LC verso la rete di distribuzione dell'energia elettrica, la quale deve evitare lo scambio di interferenze con una rete molto estesa ed accessibile a chiunque.

All'interno del filtro LC si trovano dei componenti, cablati e resinati in un contenitore tipicamente metallico zincato. Per esempio:

L1=Bobina compensata

L2-L3=Bobina di blocco

Cx=Condensatore in classe X

Cy=Condensatore in classe Y

R=Resistenza di scarica.

L1 e Cx servono principalmente per la soppressione dei disturbi in "modo differenziale".

L2, L3, Cy e L1 per la soppressione in "modo "comune".

L'attenuazione tipica (perdita di inserzione) dei filtri con singolo elemento (singola cella) varia da 30 a 50 dB. Valori intorno agli 80 dB in caso di doppio elemento (doppia cella). Ovviamente bisogna porre molta attenzione alla connessione di terra che deve essere a bassissima impedenza. Se ciò non avviene l'effetto del filtro può anche essere peggiorativo rispetto alle condizioni iniziali.

**R**ough variation in currents of loads, which are connected with power lines, generate radio frequency interferences.

Normally it defines "conducted" emission noise the interference which, through the power line wires, goes onto all the line.

The "radiated" emission noise, on the other side, is transmitted by the wires through the air as if these were antennas.

As a matter of fact, the difference is functional to phenomenon description because to each conducted noise (time dependent voltages and currents) correspond to a radiated noise. On the other side every radiated noise induces on the present wires, which work in this case as receiving antennas, an equivalent conducted electrical signal (the effectiveness of these phenomena it's, of course, frequency dependent).

Thus it is very important the rule of the LC filters to the power line distribution, which has to avoid the interferences exchange with the electrical network, by everyone used.

The typical LC filter has the following configuration:

L1=Compensated coil

L2-L3=Block coil

Cx=Class X capacitor

Cy=Class Y capacitor

R=Resistor

L1 and Cx are used for the suppression of the "differential mode" noise.

L2, L3, Cy and L1 for the one in "common mode".

The typical insertion loss of the single stage filters is approximately between 30 and 50 dB. Values around 80 dB are typical for the double stage filters.

A very important matter is the connection to the ground, which has to be at very low impedance. If this not happen, the performance of the filter can reach worst result.

# FILTRI DI RETE

POWER LINE FILTERS

## Diagrammi di attenuazione

**P**er descrivere l'efficienza di un filtro, vengono impiegati i diagrammi di attenuazione.

Da questi diagrammi si può stimare, per un disturbo noto, se un particolare filtro è adatto alla sua soppressione. Una previsione precisa può essere fatta solamente dopo una misura fisica.

Queste caratteristiche vengono misurate alimentando il filtro, attraverso circuiti prescritti, con segnali definiti. Le misure in uscita forniscono il livello di attenuazione del filtro sui disturbi.

## Insertion loss diagrams

**T**o describe filter efficiency are commonly used insertion loss diagrams.

With these diagrams it is possible to estimate, for a known "frequency placed" noise, if a particular filter is correct for its suppression. It's possible to take a definitive decision only after a measurement.

Insertion loss curves are obtained through a defined, known power source connected to the filter and superposing a noted and defined signal. The output attenuation gives a measurement of noise suppression.

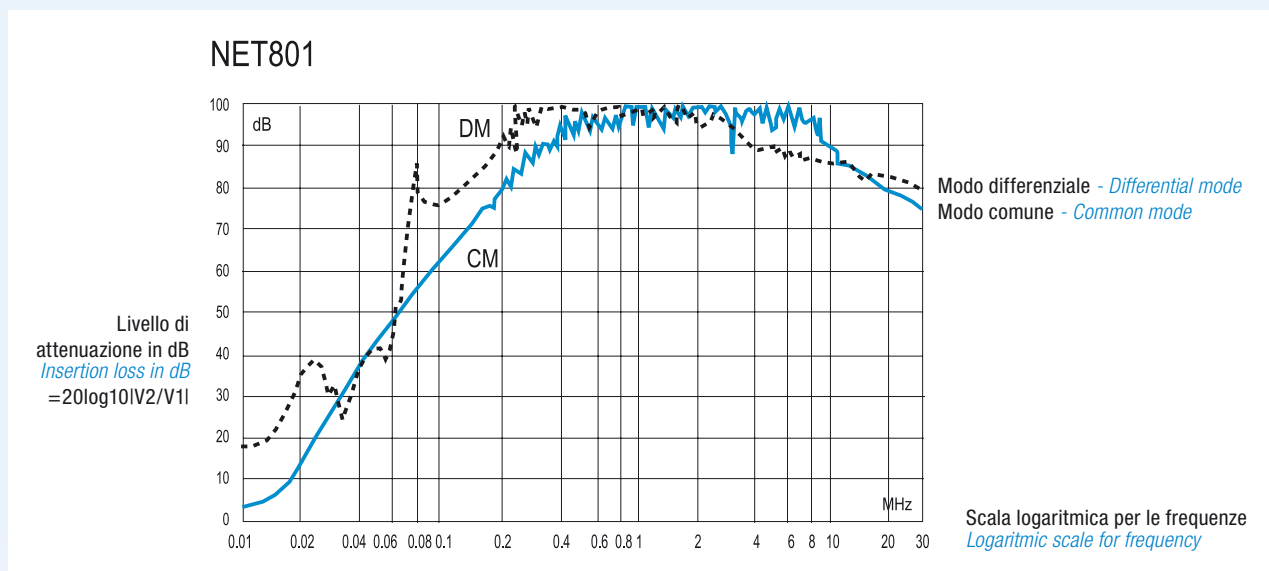

## Montaggio dei filtri Mounting

Accoppiamento - Coupling

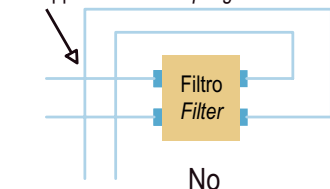

Accoppiamento - Coupling

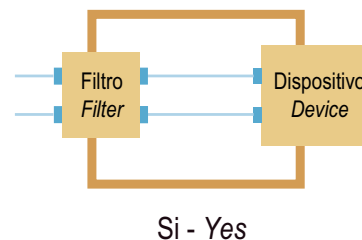
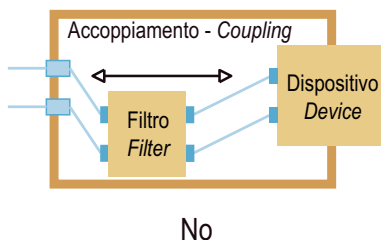
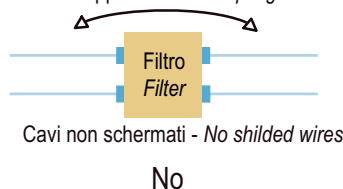

# FILTRI DI RETE

POWER LINE FILTERS

POWER LINE FILTERS FILTRI DI RETE



Tipologia - Type		Serie Series	Corrente nominale [A] Rated current [A]	Livello di attenuazione tipica - Typical insertion loss				
Ingresso - Input	Celle - Stage			0db	25dB	50dB	75dB	100dB
Monofase Single phase	1	MSC	1, 3, 6, 10, 20, 30, 35			—		
Monofase Single phase	2	MDC	3, 6, 10, 20, 30				—	
Trifase Three phase	1	TSC	5, 10			—		
Trifase Three phase	2	TDC	5, 10				—	
Trifase+N Three phase+N	2	NET	50, 80				—	—
Trifase Three phase	2	TDCL	7, 16, 30, 42, 55, 75, 100, 120, 150				—	—

**MSC**

monofase singola cella  
single phase single stage

Questo filtro di rete singola cella è indicato per qualsiasi dispositivo elettronico che richieda un filtro di linea. Disponibile per correnti da 1 a 35 A si caratterizza per una bassissima corrente di fuga che lo rende idoneo anche in campo elettromedicale. L'attenuazione media di questo filtro è pari a circa 50-60 dB. Tutti i modelli sono progettati secondo norme UL, CSA.

*This single stage filter is indicated for whichever electronic device that demands a line filter. Available with currents from 1 to 35 A it is characterized for a very low leakage current that allows to use it in electromedical field. The medium insertion loss of this filter is around 50-60 dB. All models are designed to meet UL, CSA requirements.*



**Come ordinare**  
How to order

Modello Model	Codice prodotto Code	Corrente nominale [A] Rated current [A]	Tensione nominale [V] Rated voltage [A]	L [mH]	C <sub>x2</sub> [μF]	C <sub>y</sub> [nF]	R [MΩ]	Peso [Kg] Weight [Kg]
MSC01/250	00MSC01	1	115/250	2X4	0,1	2x4,7	-	0,065
MSC03/250	00MSC03	3	115/250	2x1,5	0,01	2x3,3	-	0,150
MSC06/250	00MSC06	6	115/250	2x4	2x4,7	2x1,0	0,68	0,210
MSC10/250	00MSC10	10	115/250	2x2,4	2x4,7	2x3,3	1,5	0,190
MSC20/250	00MSC20	20	115/250	2x0,4	2x0,1	2x3,3	1,5	0,140
MSC30/250	00MSC30	30	115/250	2x0,3	2x0,1	2x3,3	1,5	0,250
MSC35/250	00MSC35	35	115/250	2x0,3	2x0,1	2x3,3	1,5	0,710
MSC03/400	0MSC034	3	400	2x1,5	0,01	2x3,3	-	0,150
MSC06/400	0MSC064	6	400	2x4	2x4,7	2x1,0	0,68	0,210

**Schema elettrico**  
Electric schematic

MSC 01

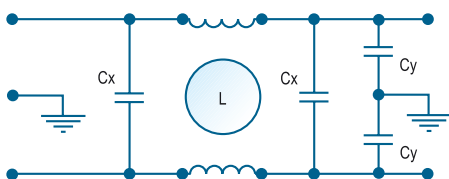

MSC 10

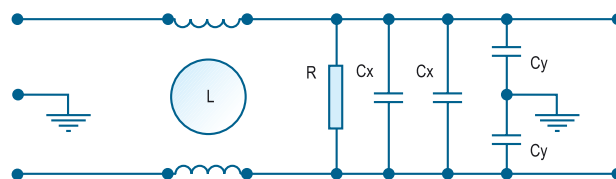

MSC 03 - MSC 03/400

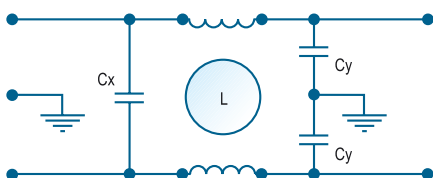

MSC 20-30-35

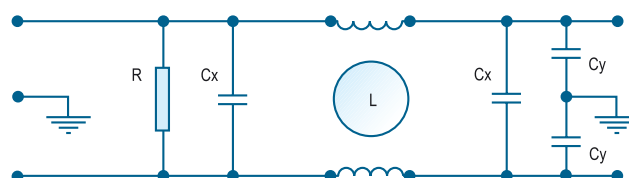

MSC 06 - MSC 06/400

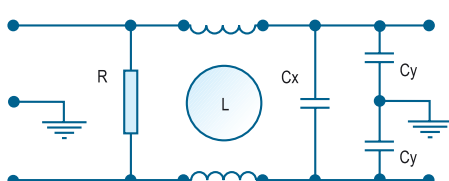

### Specifiche tecniche Specifications

Tensione d'ingresso <i>Rated voltage</i>	115/250 Vac per modelli /250; 400 Vac per modelli /400 <i>150/250 Vac for /250 models, 400 Vac for /400 models</i>
Campo di frequenza - <i>Operating frequency</i>	50 ÷ 60 Hz
Corrente di fuga - <i>Leakage current</i>	< 0,5 mA
Categoria climatica - <i>Climatic category</i>	25/085/21 (IEC 60068)
Tensione di prova DC (2 sec) - <i>Test voltage DC</i>	Fase/Terra: 2250 Vdc; Fase/Fase: 1500 Vdc - <i>Line/Ground: 2250 Vdc; Line/Line: 1500 Vdc</i>
Tensione di prova AC (1 min.) - <i>Test voltage AC</i>	Fase/Terra: 1500 Vac - <i>Line/Ground: 1500 Vac</i>
Isolamento - <i>Insulation resistance</i>	> 1500 MΩ (Fase-Terra - <i>Line/Ground</i> )
Grado di protezione - <i>IP protection</i>	IP 00 secondo EN 60529 - <i>IP 00 according to EN 60529</i>
Allacciamento - <i>Connections</i>	Fast-on eccetto MSC 30/35 (viti M4) - <i>Fast-on except models MSC 30/35 (screws M4x4)</i>
Montaggio - <i>Mounting</i>	Collegamento in serie tra la rete ed il carico. Montaggio su piastra <i>Mounted in series between the line and the load. Panel mounting</i>
Certificazioni - <i>Approvals</i>	CE; MSC 01, - 03, -06, -10, -20 sono UR listed (file E172199); il modello MSC 06 è certificato CSA <i>CE; MSC 01, -03, -06, -10, -20 are UR listed models (UL file No. E172199); MSC 06 model is CSA also</i>
Standards di riferimento - <i>Reference standards</i>	EN 60939 - UL 1283 - C22.2 No.8

### Attenuazioni (CISPR 17) Insertion loss (CISPR 17)

MSC01

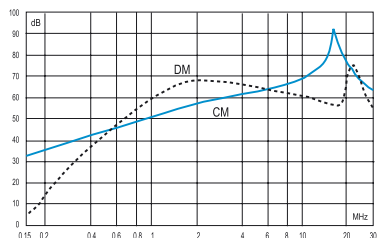

MSC03-MSC03/400

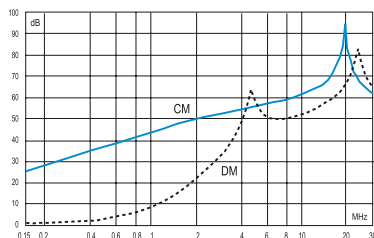

MSC06-MSC06/400

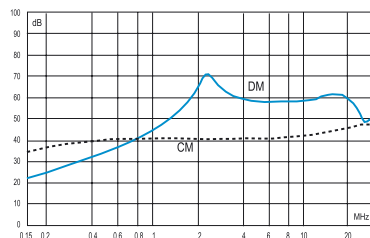

MSC10

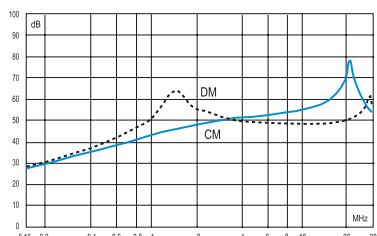

MSC20

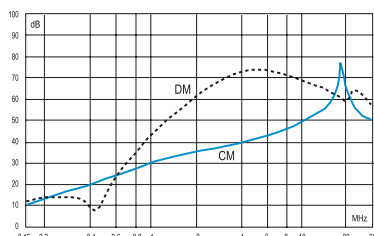

MSC30

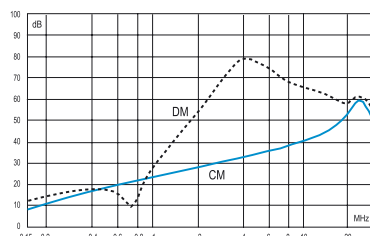

### Dimensioni [mm] Dimensions [mm]

MSC 01  
MSC 03  
MSC 03/400

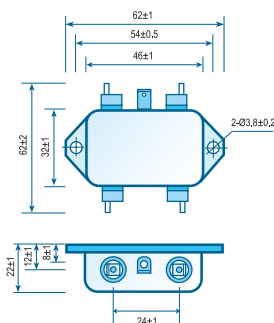

MSC 06  
MSC 06/400

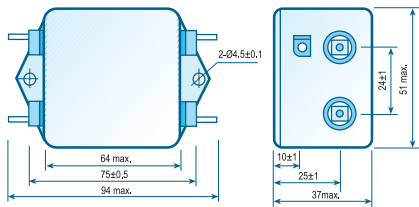

MSC 10  
MSC 20

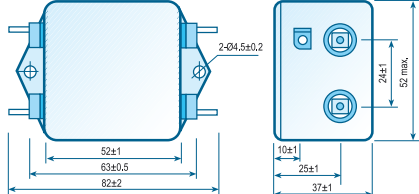

MSC 30

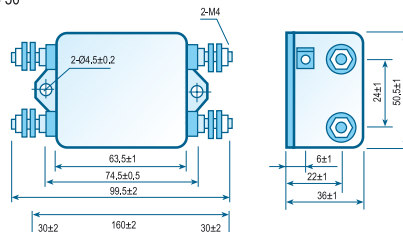

MSC 35

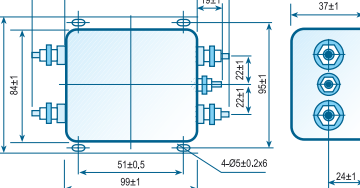

**MDC**

monofase doppia cella  
single phase double stage

Disponibile per correnti da 3 a 30 A, questo filtro monofase a doppia cella fornisce interessanti livelli di attenuazione che arrivano anche a ca. 80 dB. Su richiesta vengono realizzate serie speciali. Tutti i modelli sono progettati secondo norme UL, CSA.

Available for currents from 3 to 30 A, this double stage filter has interesting attenuation levels (up to approximately 80 dB). Special versions available on request. All models are designed to meet UL requirements.

**Specifiche tecniche**  
Specifications

Tensione d'ingresso <i>Rated voltage</i>	115/250 Vac per modelli /250; 400 Vac per modelli /400 <i>150/250 Vac for /250 models, 400 Vac for /400 models</i>
Campo di frequenza - <i>Operating frequency</i>	50÷60 Hz
Corrente di fuga - <i>Leakage current</i>	< 0,5 mA
Categoria climatica - <i>Climatic category</i>	25/085/21 (IEC 60068-1)
Tensione di prova DC (2 sec) - <i>Test voltage DC</i>	Fase/Terra: 2250 Vdc; Fase/Fase: 1500 Vdc - <i>Line/Ground: 2250 Vdc; Line/Line: 1500 Vdc</i>
Tensione di prova AC (1 min.) - <i>Test voltage AC</i>	Fase/Terra: 1500 Vac - <i>Line/Ground: 1500 Vac</i>
Isolamento - <i>Insulation resistance</i>	> 1500 MΩ (Fase-Terra - <i>Line/Ground</i> )
Grado di protezione - <i>IP protection</i>	IP 00 secondo EN 60529 - <i>IP 00 according to EN 60529</i>
Allacciamento - <i>Connections</i>	Fast-on eccetto MDC 20/30 (viti M4) - <i>Fast-on except models MDC 20/30 (screws M4x4)</i>
Montaggio - <i>Mounting</i>	Collegamento in serie tra la rete ed il carico. Montaggio su piastra <i>Mounted in series between the line and the load. Panel mounting</i>
Certificazioni - <i>Approvals</i>	CE; MDC 03, -06, -10 sono UR listed (file E172199) <i>CE; MDC 03, -06, -10 are UR listed models (UL file No. E172199)</i>
Standards di riferimento - <i>Reference standards</i>	EN 60939 - UL 1283 - C22.2 No.8

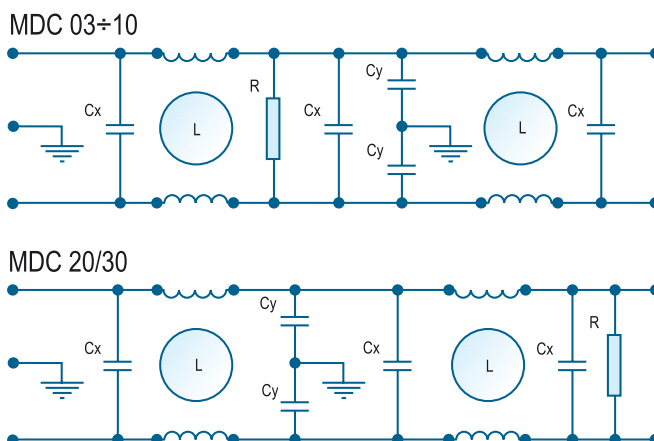
**Schema elettrico**  
Electric schematic

**Come ordinare**  
How to order

Modello Model	Codice prodotto Code	Corrente nominale [A] Rated current [A]	Tensione nominale [V] Rated voltage [V]	L [mH]	C <sub>x2</sub> [μF]	C <sub>v</sub> [nF]	R [MΩ]	Peso [Kg] Weight [Kg]
MDC03/250	00MDC03	3	115/250	2X4+2x8	3x0,47	2x3,3	1,5	0,150
MDC06/250	00MDC06	6	115/250	2x1+2x1	3x0,1	2x3,3	1,5	0,160
MDC10/250	00MDC10	10	115/250	2x0,5+2x0,5	3x0,1	2x3,3	1,5	0,160
MDC20/250	00MDC20	20	115/250	2x0,4+2x0,4	3x0,1	2x4,7	1	0,250
MDC30/250	00MDC30	30	115/250	2x0,5+2x0,5	3x0,1	2x3,3	1	0,800
MDC06/400	0MDC064	6	400	2x0,5+2x0,5	3x0,1	2x3,3	1,5	0,190

**Attenuazioni (CISPR 17)**  
Insertion loss (CISPR 17)

MDC03

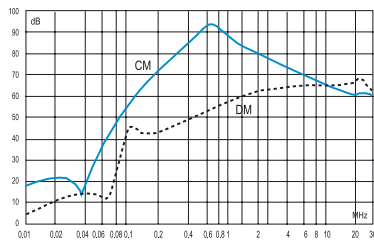

MDC06-MDC06/400

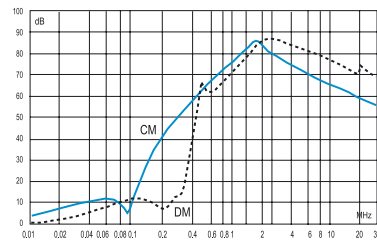

MDC10

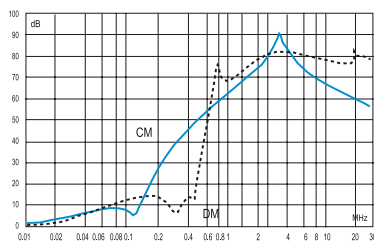

MDC20

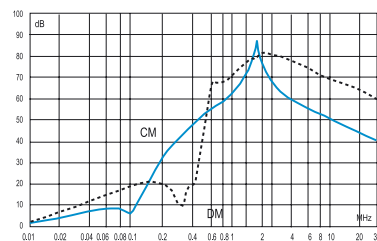

**Dimensioni [mm]**  
Dimensions [mm]

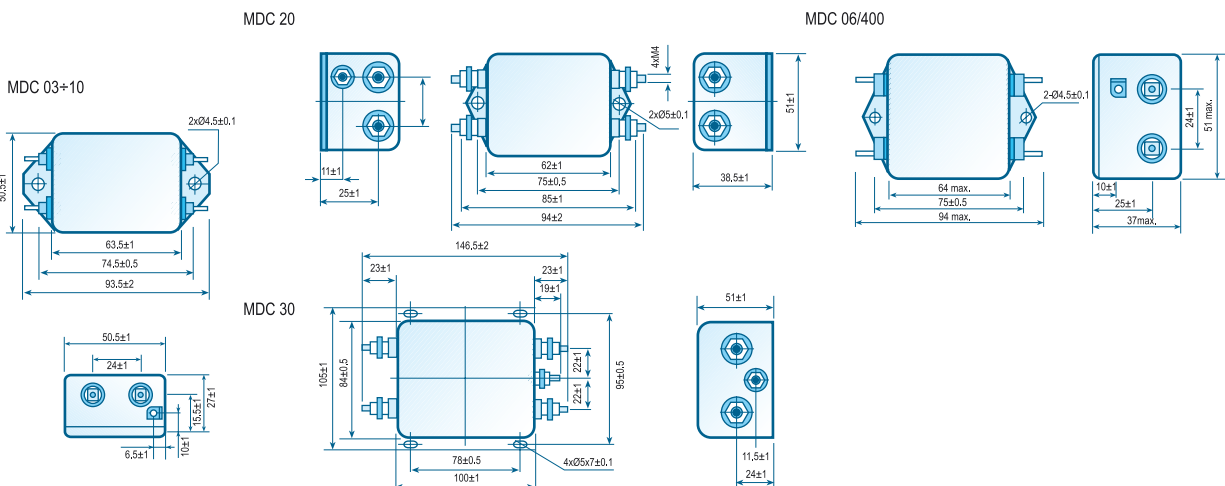

# TSC

trifase singola cella  
three phase single stage

La serie TSC è una versione economica di un filtro trifase.  
In esecuzione a singola cella, è disponibile per correnti da 5 e 10 A.  
La corrente di fuga si mantiene inferiore a 0,5 mA.

*The TSC series is a single stage filter and it is available  
for two rated currents: 5 and 10 A.  
The leakage current is maintained under 0,5 mA.*



CE

### Specifiche tecniche Specifications

Tensione d'ingresso - <i>Rated voltage</i>	250/440 Vac
Campo di frequenza - <i>Operating frequency</i>	50 ÷ 60 Hz
Corrente di fuga - <i>Leakage current</i>	< 0,5 mA
Categoria climatica - <i>Climatic category</i>	25/085/21 (IEC 60068-1)
Tensione di prova DC (2 sec.) - <i>Test voltage DC</i>	Fase/Terra: 2250 Vdc; Fase/Fase: 1500 Vdc - Line/Ground: 2250 Vdc; Line/Line: 1500 Vdc
Tensione di prova AC (1 min.) - <i>Test voltage AC</i>	Fase/Terra: 1500 Vac - Line/Ground: 1500 Vac
Isolamento - <i>Insulation resistance</i>	> 1500 MΩ (Fase-Terra - Line/Ground)
Grado di protezione - <i>IP protection</i>	IP 00 secondo EN 60529 - IP 00 according to EN 60529
Allacciamento - <i>Connections</i>	Fast-on
Montaggio - <i>Mounting</i>	Collegamento in serie tra la rete ed il carico. Montaggio su piastra <i>Mounted in series between the line and the load. Panel mounting</i>
Certificazioni - <i>Approvals</i>	CE
Standards di riferimento - <i>Reference standards</i>	EN 60939 - UL 1283 - C22.2 No.8

### Schema elettrico Electric schematic

TSC 05 - TSC 10

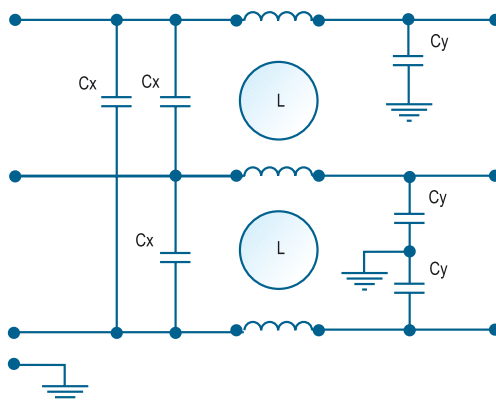

**Come ordinare**  
How to order

Modello Model	Codice prodotto Code	Corrente nominale [A] Rated current [A]	Tensione nominale [V] Rated voltage [V]	L [mH]	C <sub>x2</sub> [μF]	C <sub>y</sub> [nF]	R [MΩ]	Peso [Kg] Weight [Kg]
TSC05	00TSC05	5	250/440	3X1,5	3x0,1	3x6,8	-	0,215
TSC10	00TSC10	10	250/440	3x1,2	3x0,1	3x6,8	-	0,220

**Attenuazioni (CISPR 17)**  
Insertion loss (CISPR 17)

TSC05

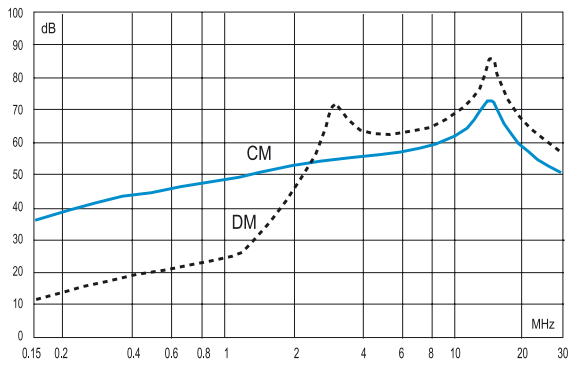

TSC10

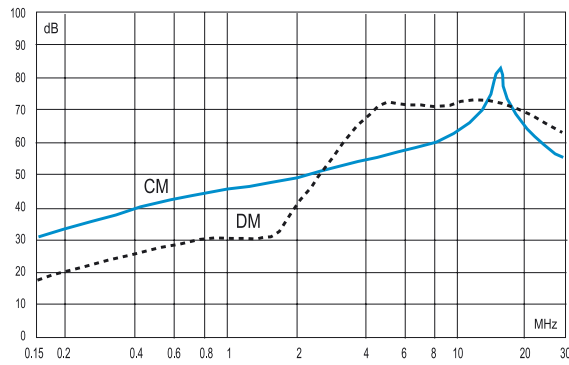

**Dimensioni [mm]**  
Dimensions [mm]

TSC 05 - TSC 10

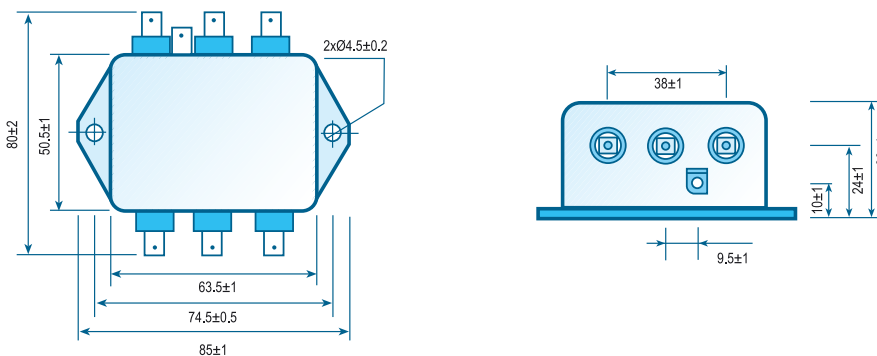

**TDC**

trifase doppia cella  
three phase double stage

Questo modello rappresenta il "top" della gamma. Nato espressamente per filtrare i critici livelli di rumore generati da convertitori di frequenza, denota valori di attenuazione estremamente elevati nel campo frequenze dai 150 kHz ai 600 kHz, normalmente i più difficili da ottenere. Gli elevatissimi livelli di attenuazione sono ottenuti mantenendo la corrente di fuga a valori estremamente contenuti.

*This model represents the "top" of the range. Expacially designed in order to filter the critical noise level generated from frequency converters, shows attenuation values extremely elevates in the frequencies range from 150 to 600 kHz, normally most difficult to obtain. The highest levels of attenuation are obtained also maintaining the leakage current to extremely low values.*



CE

**Specifiche tecniche**  
Specifications

Max. tensione d'ingresso - <i>Max. rated voltage</i>	300/520 Vac
Campo di frequenza - <i>Operating frequency</i>	50 ÷ 60 Hz
Corrente di fuga - <i>Leakage current</i>	< 0,5 mA
Categoria climatica - <i>Climatic category</i>	40/085/21 (IEC 60068-1)
Tensione di prova DC (2 sec) - <i>Test voltage DC</i>	Fase/Terra: 2250 Vdc; Fase/Fase: 1500 Vdc - <i>Line/Ground: 2250 Vdc; Line/Line: 1500 Vdc</i>
Tensione di prova AC (1 min) - <i>Test voltage AC</i>	Fase/Terra: 1500 Vac - <i>Line/Ground: 1500 Vac</i>
Isolamento - <i>Insulation resistance</i>	> 1500 MΩ (Fase-Terra - <i>Line/Ground</i> )
Grado di protezione - <i>IP protection</i>	IP 00 secondo EN 60529 - <i>IP 00 according to EN 60529</i>
Contenitore/Riempitivo - <i>Enclosure/Potting material</i>	Acciaio placcato nichel / Resina epossidica UL94-V0 - <i>Nickel plated sheet steel / Epoxy resin UL94-V0</i>
Allacciamento - <i>Connections</i>	Viti - <i>Screws</i>
Montaggio - <i>Mounting</i>	Collegamento in serie tra la rete ed il carico. Montaggio su piastra <i>Mounted in series between the line and the load. Panel mounting</i>
Certificazioni - <i>Approvals</i>	CE
Standards di riferimento - <i>Reference standards</i>	EN 60939 - UL 1283 - C22.2 No.8

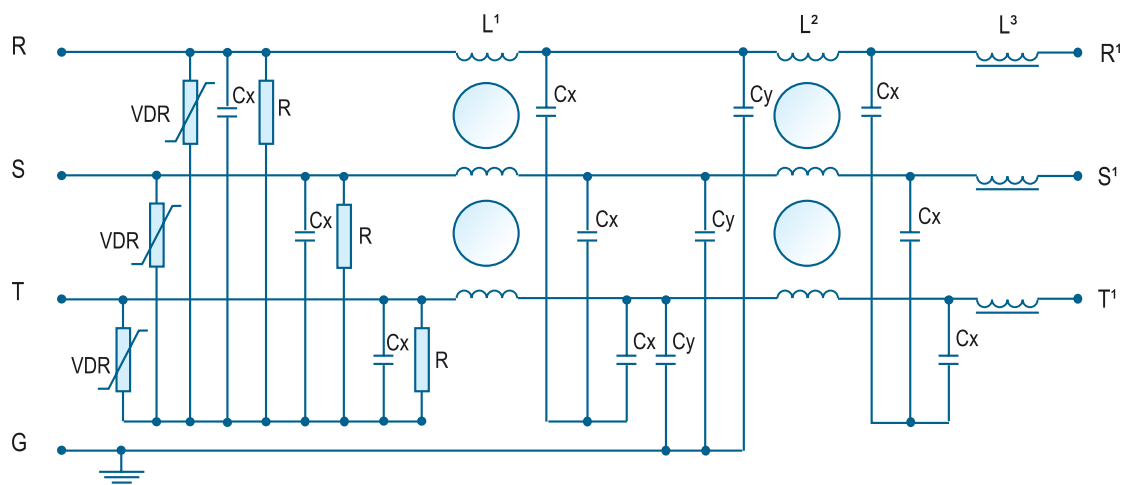
**Schema elettrico**  
Electric schematic

**Come ordinare**  
How to order

Modello Model	Codice prodotto Code	Corrente nominale [A] Rated current [A]	L1[mH]	L2[mH]	L3[mH]	C <sub>x2</sub> [μF]	C <sub>y</sub> [nF]	R[MΩ]	Peso [Kg] Weight [Kg]
TDC05	00TDC05	5	3,3	3x1,2	3X5	2,2	47	3x5,5x10 <sup>-2</sup>	1,6
TDC10	00TDC10	10	3,3	3x1,2	3X5	2,2	47	3x2,6x10 <sup>-2</sup>	1,6

Sono disponibili modelli fino a 20 A - We have available models up to 20 Amps.

**Attenuazioni (CISPR 17)**  
Insertion loss (CISPR 17)

TDC05

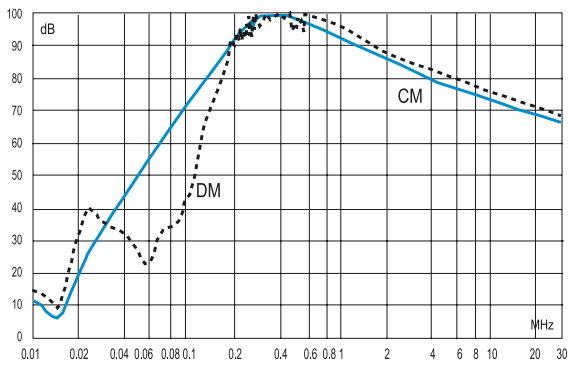

TDC10

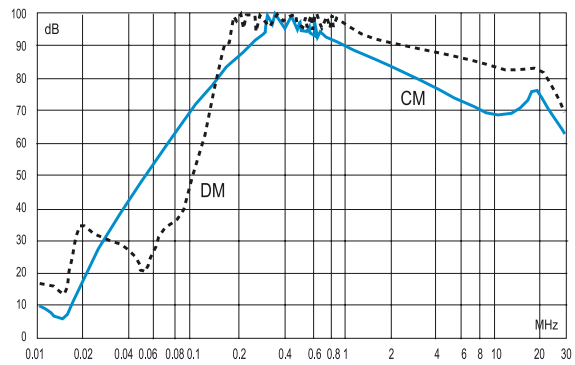

**Dimensioni [mm]**  
Dimensions [mm]

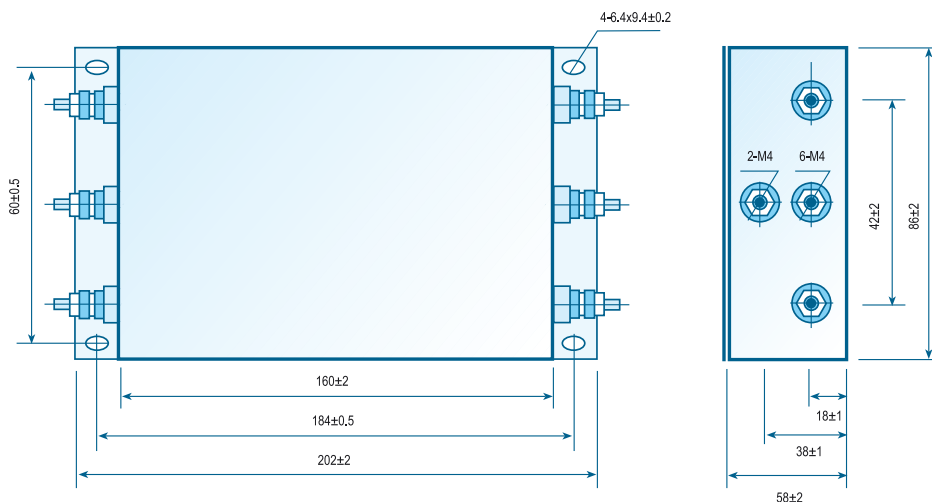

**NETxx1**

trifase + neutro  
three phase + N

Questo modello di filtro trifase più neutro è ideale per convertitori di frequenza e per tutte le situazioni ad elevato disturbo. Offre infatti una elevatissima attenuazione nella banda tra i 150 kHz e i 600 kHz. Questi filtri sono progettati secondo norme UL.

*This model of threephase+N is suitable to suppress noise generated from frequency converters and effective for all situation when high level of noise are present. These filters have very high insertion loss between 150 kHz and 600 kHz. These filters are designed to meet UL requirements.*

**Specifiche tecniche**  
Specifications

Max. tensione d'ingresso - <i>Max. rated voltage</i>	300/520 Vac
Campo di frequenza - <i>Operating frequency</i>	50÷60 Hz
Corrente di fuga - <i>Leakage current</i>	< 9 mA (NET501); <20 (NET801)
Categoria climatica - <i>Climatic category</i>	40/085/21 (IEC 60068-1)
Tensione di prova DC (2 sec) - <i>Test voltage DC</i>	Fase/Terra: 2250 Vdc; Fase/Fase: 1500 Vdc - <i>Line/Ground: 2250 Vdc; Line/Line: 1500 Vdc</i>
Tensione di prova AC (1 min) - <i>Test voltage AC</i>	Fase/Terra: 1500 Vac - <i>Line/Ground: 1500 Vac</i>
Isolamento - <i>Insulation resistance</i>	> 1500 MΩ (Fase-Terra - <i>Line/Ground</i> )
Grado di protezione - <i>IP protection</i>	IP 00 secondo EN 60529 - <i>IP 00 according to EN 60529</i>
Contenitore/Riempitivo - <i>Enclosure/Potting material</i>	Acciaio placcato nichel / Resina epossidica UL94-V0 - <i>Nickel plated sheet steel / Epoxy resin UL94-V0</i>
Allacciamento - <i>Connections</i>	Viti - <i>Screws</i>
Montaggio - <i>Mounting</i>	Collegamento in serie tra la rete ed il carico. Montaggio su piastra <i>Mounted in series between the line and the load. Panel mounting</i>
Certificazioni - <i>Approvals</i>	CE, UR listed (modello NET501 e NET801) - <i>CE, UR listed (NET501 and NET801 models)</i>
Standards di riferimento - <i>Reference standards</i>	EN 60939 - UL 1283 - C22.2 No.8

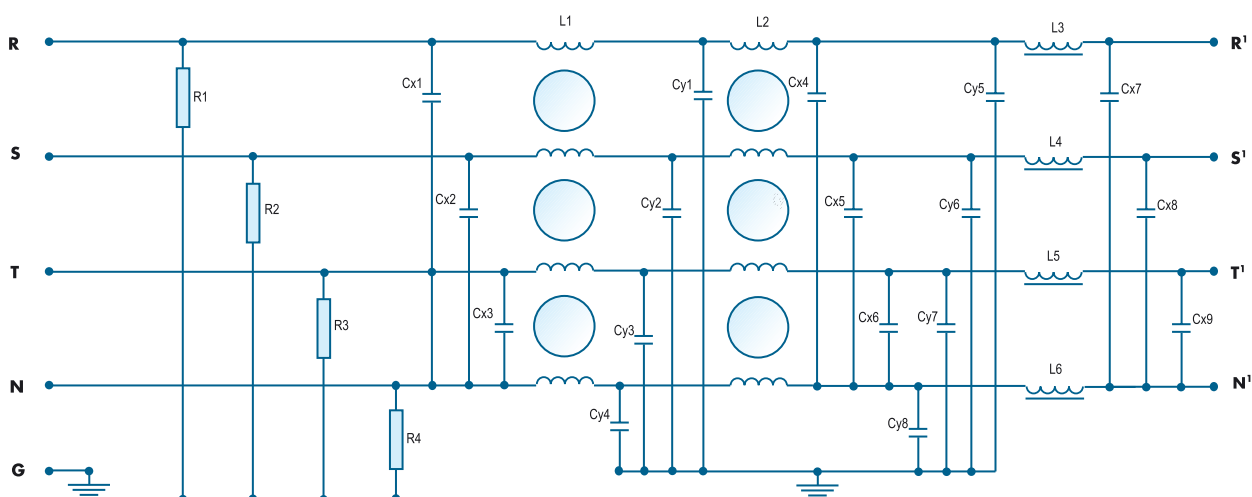
**Schema elettrico**  
Electric schematic

**Come ordinare**  
How to order

Modello Model	Codice prodotto Code	Corrente nominale [A] Rated current [A]	L1[mH]	L2[mH]	L3~L6 [μH]	C <sub>x1</sub> ~C <sub>x9</sub> [μF]	C <sub>y1</sub> ~C <sub>y8</sub> [μF]	R1~R4 [kΩ]	Peso [Kg] Weight [Kg]
NET501	ONET501	50	4x0.6	4x0.5	2	2.2	0.047	220	4,7
NET801	ONET801	80	4x0.25	4x0.25	2	10	0.1	220	11

**Attenuazioni (CISPR 17)**  
Insertion loss (CISPR 17)

NET501

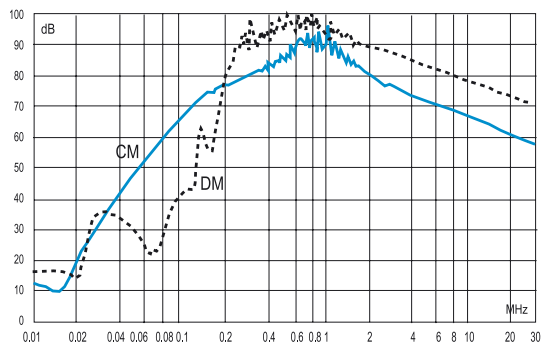

NET801

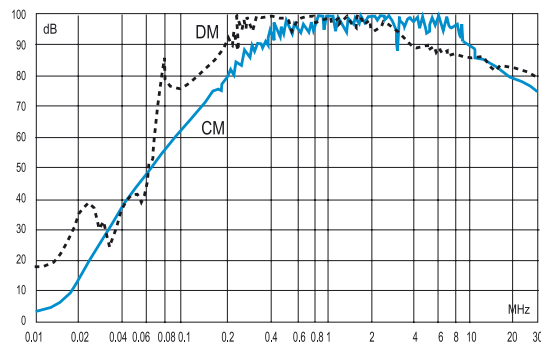

**Dimensioni [mm]**  
Dimensions [mm]

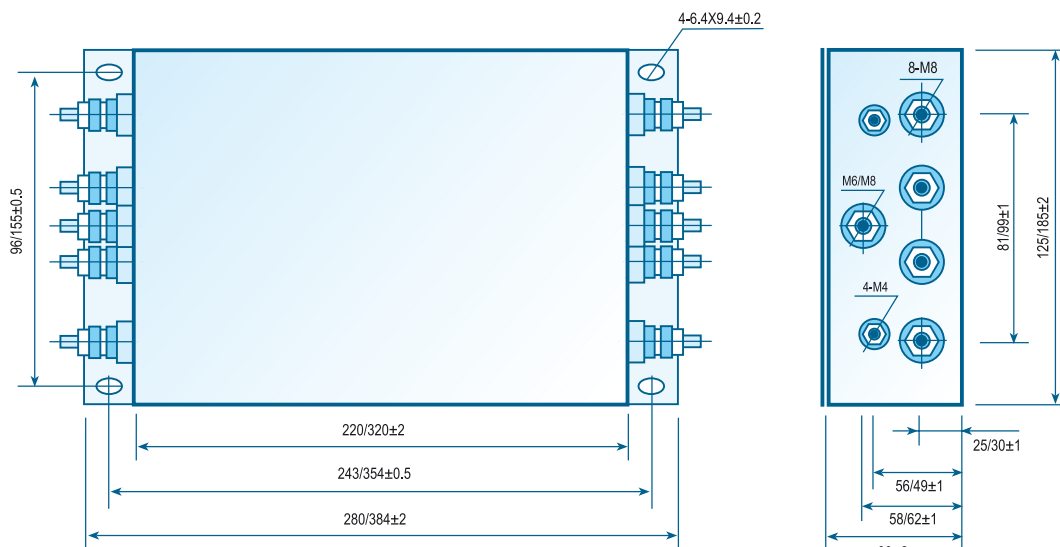

# TDCL

trifase doppia cella a libro  
*three phase double stage bookshelf design*

Filtro per convertitori/inverter  
 Configurazione delta  
 Compatto, leggero  
 Formato a libro  
 Correnti nominali da 1 a 150A  
 Alta attenuazione

*3 phase filter for drives/inverters  
 Delta configuration  
 Compact, light weight  
 Bookshelf design  
 1-150A current rating  
 High insertion loss*



**Come ordinare**  
*How to order*

Modello <i>Model</i>	Codice prodotto <i>Code</i>	Corrente nom. [A] <i>Rated current [A]</i>	Capacità [μF] - <i>Capacitance [μF]</i>				R1 [MΩ/W]	R2 [KΩ/W]	L1	L2	Peso [Kg] <i>Weight [Kg]</i>
			C <sub>X1</sub>	C <sub>X2</sub>	C <sub>X3</sub>	C <sub>Y1</sub> , C <sub>Y2</sub>					
TDCL07	2390TDCL07	7	1	1	1	0,47	1.5/1	680/1	5mH	5mH	1,1
TDCL16	2390TDCL16	16	1	1	1	0,47	1.5/1	680/1	4mH	4mH	1,6
TDCL30	2390TDCL30	30	1	1	1	0,47	1.5/1	680/1	2.4mH	2.4mH	2,25
TDCL42	2390TDCL42	42	1	1	1	1	1.5/1	680/1	1.5mH	1.5mH	2,4
TDCL55	2390TDCL55	55	1	1	1	1	1.5/1	680/1	600μH	600μH	2,95
TDCL75	2390TDCL75	75	2.2	2.2	2.2	1	1.5/2	680/2	350μH	350μH	4
TDCL100	239TDCL100	100	4.4	4.4	4.4	1	1.5/2	680/2	150μH	150μH	5,6
TDCL120	239TDCL120	120	4.4	4.4	4.4	1	1.5/2	680/2	100μH	100μH	7,4
TDCL150	239TDCL150	150	4.4	4.4	4.4	1	1.5/2	680/2	100μH	100μH	8,9

**Attenuazioni (CISPR 17)**  
*Insertion loss (CISPR 17)*

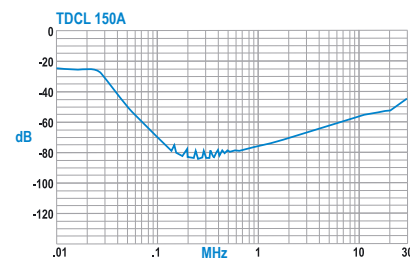
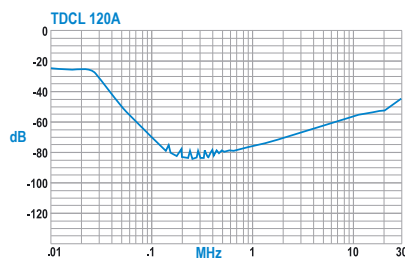
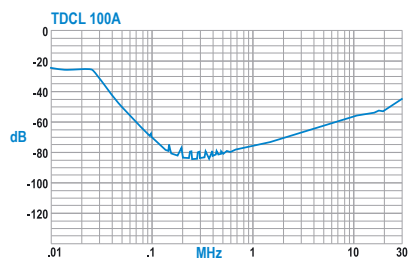
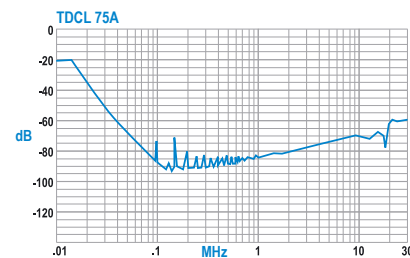
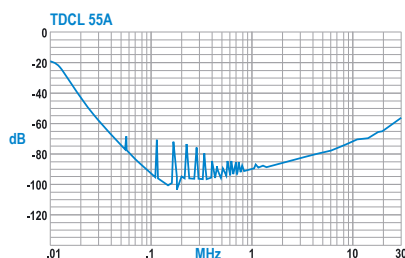
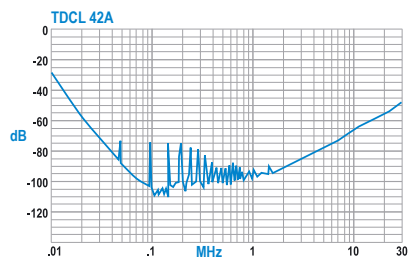
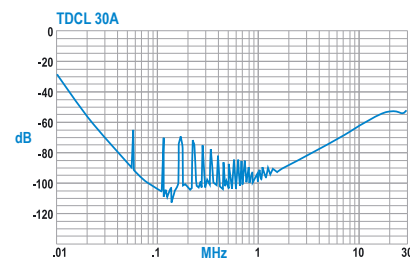
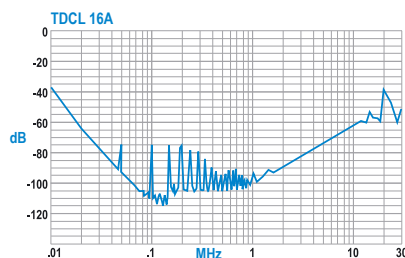
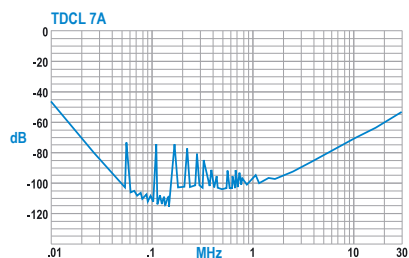

### Specifiche tecniche Specifications

Tensione d'ingresso - <i>Rated voltage</i>	440 Vac
Campo di frequenza - <i>Operating frequency</i>	50 ÷ 60 Hz
Corrente di fuga - <i>Leakage current</i>	<3 mA (@250 Vac)
Categoria climatica - <i>Climatic category</i>	25/085/21 (IEC 60068)
Tensione di prova DC (2 sec) - <i>Test voltage DC</i>	Fase/Terra: 2760 Vdc; Fase/Fase: 2090 Vdc - <i>Line/Ground: 2760 Vdc; Line/Line: 2090 Vdc</i>
Tensione di prova AC (1 min.) - <i>Test voltage AC</i>	Fase/Terra: 1500 Vac - <i>Line/Ground: 1500 Vac</i>
Sovraccaricabilità - <i>Current overload</i>	6 x corrente nom. per 8 sec. - <i>6 x rated current for 8 sec.</i>
Isolamento - <i>Insulation resistance</i>	> 1500 M (Fase/Terra - <i>Line/Ground</i> )
Grado di protezione - <i>IP protection</i>	IP 00 secondo EN 60529 - <i>IP 00 according to EN 60529</i>
Allacciamento - <i>Connections</i>	Morsetti - <i>Terminals</i>
Montaggio - <i>Mounting</i>	Collegamento in serie tra la rete ed il carico. Montaggio su piastra. <i>Mounted in series between the line and the load. Panel mounting.</i>
Certificazioni - <i>Approvals</i>	CE / CSA / C-US
Standard di riferimento - <i>Reference standards</i>	EN 60939 - UL 1283 - C22.2 No.8

### Schema elettrico Electric schematic

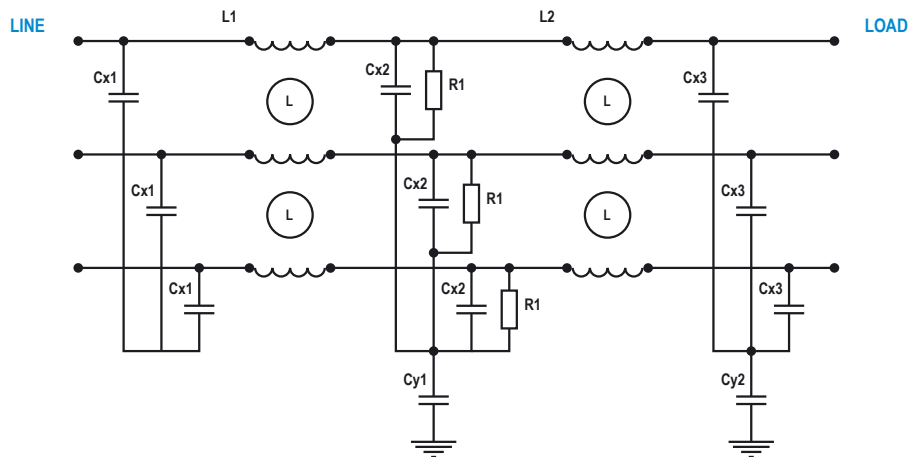

### Dimensioni [mm] Dimensions [mm]

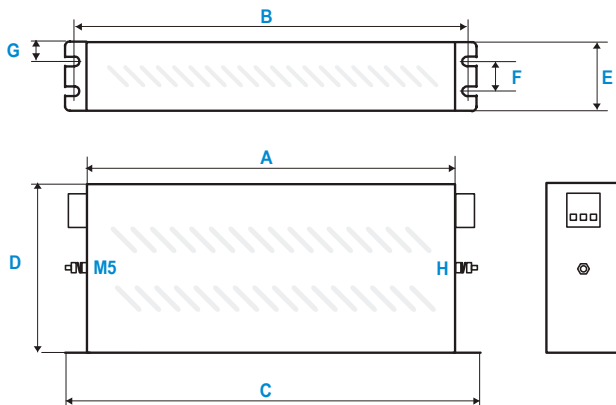

Corrente nominale <i>Current rating</i>	A	B	C	D	E	F	G	H
7A	195	215	255	95	65	30	4,5	M5
16A	275	285	300	95	65	35	5,4	M5
30A	300	315	330	110	70	40	5,4	M5
42A	300	315	330	110	70	40	5,4	M6
55A	280	300	315	105	85	75	5,4	M6
75A	320	335	350	150	90	75	6,5	M6
100A	320	335	350	170	100	80	6,5	M10
120A	320	335	350	170	100	80	6,0	M10
150A	320	335	350	170	100	80	6,0	M10