

MITSUBISHI

General Purpose Inverter

FREQROL-U_{120S}-EC

European version

Instruction Manual

Thank you for choosing the Mitsubishi Inverter.

This instruction manual gives handling information and precautions for use of this equipment. Incorrect handling might cause an unexpected fault. Before using the inverter, please read this manual carefully. Please forward this manual to the end user.

This section is specifically about safety matters

Do not attempt to install, operate, maintain or inspect the inverter until you have read through this instruction manual and appended documents carefully and can use the equipment correctly. Do not use the inverter until you have a full knowledge of the equipment, safety information and instructions. In this instruction manual, the safety instruction levels are classified into "WARNING" and "CAUTION".

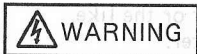

Assumes that incorrect handling may cause hazardous conditions, resulting in death or severe injury.

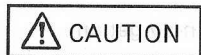









Assumes that incorrect handling may cause hazardous conditions, resulting in medium or slight injury, or may cause physical damage only.

Note that the CAUTION level may lead to serious consequence according to conditions. Please follow the instructions of both levels because they are important to personnel safety.

SAFETY INSTRUCTIONS



1. Electric shock prevention

WARNING

-  While power is on or when the inverter is running, do not open the front cover. You may get an electric shock.
-  Do not run the inverter with the front cover removed. Otherwise, you may access the exposed highvoltage terminals and charging part and get an electric shock.
-  If power is off, do not remove the front cover except for wiring or periodic inspection. You may access the charged inverter circuits and get an electric shock.
-  Before starting wiring or inspection, switch power off, wait for more that 10 minutes, and check for no residual voltage with a tester or the like.
-  Use a class 3 or higher earthing method to earth the inverter.
-  Any person who is involved in the wiring or inspection of this equipment should be fully competent to do the work.
-  Always install the inverter before wiring. Otherwise, you may get an electric shock or be injured.
-  Operate the switches with dry hands to prevent an electric shock.
-  Do not subject the cables to scratches, excessive stress, heavy loads or pinching. Otherwise, you may get an electric shock.





2. Fire Prevention

CAUTION

-  Mount the inverter on an incombustible surface. Installing the inverter directly on or near a combustible surface could lead to a fire.
-  If the inverter has become faulty, switch power off on the inverter's power supply side. A continuous flow of a large current could cause a fire.

3. Injury Prevention

CAUTION











-  Apply only the voltage specified in the instruction manual to each terminal to prevent, damage, etc.
-  Ensure that the cables are connected to the correct terminals. Otherwise damage, etc. may occur.
-  Always make sure that polarity is correct to prevent damage, etc.
-  Please be careful, the key pad and plastic enclosure are hot when operating over 40°C ambient temperature.
-  While power is on or for some time after power-off, do not touch the inverter as it is hot and you may get burnt.

4. Additional instructions

To prevent injury, damage, or product failure, please note the following points.

(1) Transportation and mounting

CAUTION

-  Take care when carrying products, use correct lifting gear.
-  Do not stack the inverter boxes higher than the number recommended.
-  Ensure the installation position and material can withstand the weight of the inverter. Install according to the information in the Instruction Manual.
-  Do not operate if the inverter is damaged or has parts missing.
-  Do not lift the inverter with the front cover attached, it may fall off.
-  Do not stand or rest heavy objects on the inverter.
-  Check the inverter mounting orientation is correct.
-  Prevent any dust, wire fragments or other foreign bodies from dropping into the inverter during wiring up and commissioning.
-  Do not drop the inverter, or subject it to impacts.
-  Use the inverter under the following environmental conditions:



 CAUTION

Environment	Conditions
Ambient temperature	-10°C to +50°C (non-freezing)
Ambient humidity	90%RH or less (non-condensing)
Storage temperature	-20 to +65°C *
Ambience	Indoors, free from corrosive gas, flammable gas, oil mist, dust and dirt.
Altitude, vibration	Max. 1000m above sea level, 5.9m/S ² (0.6G) or less (conforming to JIS C 0911)

* Temperatures applicable for a short time, e.g. in transit.

(2) Wiring

 CAUTION

-  Do not fit capacitive equipment such as power factor correction capacitor, noise filter or surge suppressor to the output of the inverter.
-  The connection orientation of the output cables U, V, W to the motor will effect the direction of rotation of the motor.





(3) Trial run

CAUTION

-  Check all parameters, and ensure that the machine will not be damaged by sudden start-up.

(4) Operation

CAUTION

-  While the retry function is selected, keep away from the equipment because it will start suddenly after an alarm stop.
-  The stop key valid only when function setting has been made. Prepare an emergency stop switch separately.
-  Switch off the start signal when resetting the inverter. Failure to do so may start the motor immediately after reset.
-  Do not use for loads other than a 3-phase induction motor. If another electrical device is connected to the inverter output the device could be damaged.
-  Do not modify the equipment.

⚠ CAUTION

- ⚠ The electronic motor thermal protection does not guarantee to prevent motor burn out.
- ⚠ Do not use a contactor on the inverter input for frequent starting/stopping of the inverter. use control signals.
- ⚠ To reduce the effect of mains conducted electromagnetic interference use a RFI noise filter. Take care to ensure electromagnetic radiation from the inverter does not damage or effect the operation of nearby electrical equipment.
- ⚠ When parameter clear or all parameter clear is performed, each parameter returns to the factory setting. Re-set the required parameters before starting operation.
- ⚠ The inverter can be easily set for high-speed operation. Before changing its setting, fully examine the performances of the motor and machine.
- ⚠ The inverter does not have a holding stop facility. For emergency stop another circuit must be used.

(5) Emergency stop

 CAUTION

 Provide a safety backup such as emergency brake which will prevent the machine and equipment from hazardous conditions if the inverter fails.

(6) Maintenance, inspection and parts replacement

 CAUTION

 Do not carry out a megger (insulation resistance) test on the control circuit of the inverter.

(7) Disposing of the inverter.

 CAUTION

 Treat as industrial waste.

(8) General

Many of the diagrams and drawings in the instruction manual show the inverter without a cover, or partially open. Never run the inverter like this. Always replace the cover and follow this instruction manual when operating the inverter.

INSTRUCTIONS FOR COMPLIANCE WITH THE EUROPEAN DIRECTIVES

1. EMC DIRECTIVE

(1) Our view of inverters and the EMC Directive

An inverter does not function independently. It is a component designed for installation in a control box and for use with other equipment to control a machine or equipment. Therefore, we do not think that the EMC Directive applies directly to inverters. For this reason, we do not place the CE mark on the inverters themselves. The European power drive manufacturers' organization (CEMEP) also holds this point of view.

(2) Compliance

We do not think that the inverters themselves are covered directly by the EMC Directive. However, the EMC Directive applies to machines and equipment into which inverters have been incorporated, and these machines and equipment must carry the CE mark. Hence, we have prepared a technical document "EMC Installation Guidelines" (manual number BCN-A21041-202) so that machines and equipment incorporating inverters may conform to the EMC Directive more easily.

(3) Outline of installation method

It is recommended to install an inverter in the following method:

- * Use the inverter with an European Standard-compliant noise filter.
- * For wiring between the inverter and motor, use shielded cables or run

cables in metal conduit and ground the cables or conduit at the inverter and motor ends. Use the shortest possible cable length.

* Install the inverter in an earthed metal enclosure. The enclosure should prevent radiated noise leakage.

* Insert a line noise filter and ferrite core into the power and control lines as required.

Full information including the European Standard-compliant noise filter specifications are published in the "EMC Installation Guidelines" (number BCN-A21041-202). Please contact your sales representative.

2. Low Voltage Directive

(1) Our view of inverters for the Low Voltage Directive
Inverters are covered by the Low Voltage Directive.

(2) Compliance

The European verification institution has approved that our inverters conform to DIN VDE0160. Therefore, the CE mark is placed on inverters.

(3) Instructions

To conform to DIN VDE0160, the following specifications and instructions listed are different from those of the standard models.

* Use inverter under condition of Over Voltage Category II, Pollution Degree 2 or better.

- * Do not use residual current device as the only protection against indirect contact. Protective earth connection is essential.
- * Wire the earth terminal independently. (Do not connect two or more cables.) Connect motor earth to the earth of panel.
- * Only use EN or IEC compliant no-fuse breakers and magnetic contactors.
- * In the input of the inverter, insert an EN or IEC Standard-compliant isolation transformer or surge suppressor. (Not required when the operating place falls within the overvoltage category II set forth in IEC664.)
- * For the input and output of the inverter, only use cables of the type and size set forth in EN60204 Appendix C.
- * Inverter is considered as built-in component. EMC regulations should be considered for whole machinery system.
- * Maximum transportation altitude is 10,000m.

Thank you for purchasing the Mitsubishi general purpose inverter FREQROL-U100.
For safe operation, please read this manual thoroughly before using this device.

Table of Contents

1. INSPECTION AT DELIVERY	1
2. NAMES AND FUNCTIONS OF EACH PART	2
3. INSTALLATION	5
4. WIRING	7
■ Precautions for wiring	7
■ Connecting power supply and motor	8
■ Connecting control signals	9
■ Wire size and peeling length	11
5. OPERATION	14
■ Operation methods	14
■ How to use the key pad	17
■ Monitor and parameter settings	18
6. FUNCTIONS	20
■ List of functions	20
■ Explanation of functions	25

7. SPECIFICATIONS	67
■ Standard specifications	67
■ Common specifications	68
■ Terminal wiring diagram	70
■ Explanation of terminal specifications	72
■ Protective function	76
8. DIMENSIONAL OUTLINE DRAWING	80
■ FR-U120S	80
9. SELECTION OF PERIPHERAL DEVICES	82
10. OPTION	84

1. INSPECTION AT DELIVERY

Confirm the following points when unpacking the device.

- (1) Check the model plate on the front of the inverter and the rating plate on the side and check that the delivered device is the same as that ordered.
- (2) Check for damage caused during shipment.

If there are any unclear points or damage is found in the device, please contact the place of purchase or your nearest Mitsubishi dealer.

FR-U120S-N0.2K-EC A3129

Inverter model Manufacturing No.

Details of model plate

MITSUBISHI INVERTER	
MODEL	FR-U120S-N0.2K-EC
POWER	0.2kW
AC INPUT	AC220V-240V 50/60Hz
OUTPUT	1.4A
SERIAL	A31290007
MITSUBISHI ELECTRIC CORPORATION MADE IN JAPAN	

← Inverter model
← Motor capacity
← Power supply
← Rated output current
← Manufacturing No.

Details of rating plate

Details of model

FR-U120S-N 0.4K-EC

Symbol	Applicable motor capacity
0.2K to 0.75K	The capacity is shown in kW units.

2. NAMES AND FUNCTIONS OF EACH PART

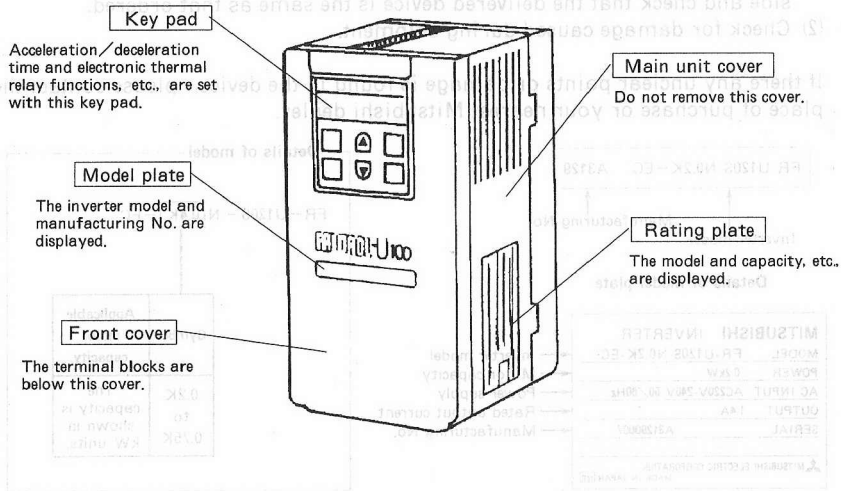

State with front cover removed

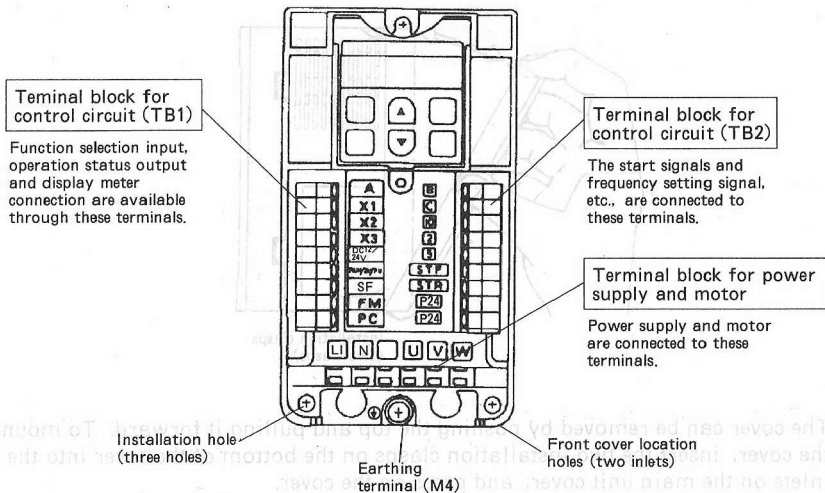

How to remove/mount front cover

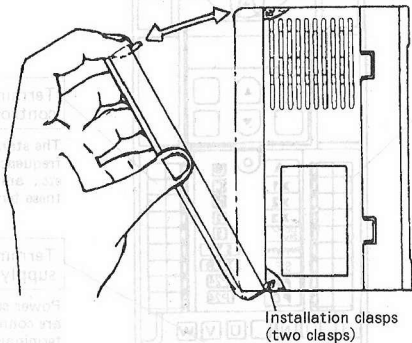

The cover can be removed by pushing the top and pulling it forward. To mount the cover, insert the two installation clasps on the bottom of the cover into the inlets on the main unit cover, and press on the cover.

3. INSTALLATION

- **Install the inverter vertically.**

Non-vertical installation methods will cause the inverter's heat dissipating effect to decrease, and may cause unforeseen problems and breakdowns.



Right
Vertical
installation



Wrong
Horizontal
installation



Wrong
Sideways
installation

- **Keep the ambient temperature within the permissible temperature range.**

If the inverter's ambient temperature rises due to installation near a heat generating object or installation in a panel will cause the inverter life to decrease remarkably.

Take cooling methods and panel dimensions into consideration when installing the inverter in a panel.

- Tolerable ambient temperature : -10 to 50°C
- Points for measuring ambient temperature

Note : The inverter was designed for use in separately earthed enclosure.
Precautions must therefore be taken at point of installation to minimise risk of hazard to users.

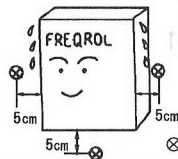

⊗ Measurement
position

- **Ambient space**

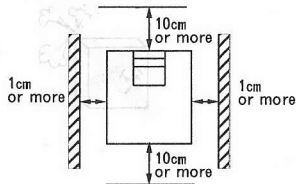

● Avoid installation in the following places

- Where the inverter is subject to direct sunlight
- Humid places
- Places contaminated with oil mist, dust, lint or corrosive gases. Where the inverter is subject to wind containing salt.
- Places that vibrate

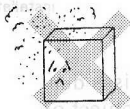
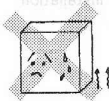

Avoid dollies and press machines, etc.

- Places where explosive gases exist.
- Installation on flammable material such as wood.

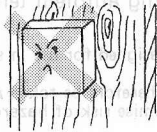
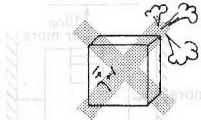

4. WIRING

■ Precautions for wiring

Pay attention to the following items during wiring to prevent hazard to users.

Precautions during wiring

- (1) When the power supply is applied on the inverter output terminals (U, V and W); the inverter will be damaged. Never wire the power supply to these terminals.
- (2) Use a shield or twisted wire for the wiring to the control circuit terminals, and separate the wires from the main circuit or power distribution circuit (200V relay sequence circuit, etc.).
- (3) Cover the slits on the inverter so that the wire waste does not enter the inverter during wiring.
- (4) Confirm that the display lamp on the key pad has gone out before changing the wiring after operation, and wait at least two minutes before starting the wiring. (It takes more than one minutes for discharge of the internal capacitors after disconnecting power supply.)

■ Connecting power supply and motor

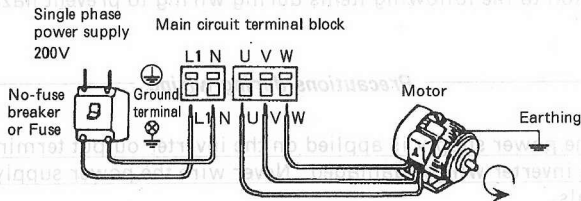

Always connect the power supply wires to L1 and N.

Never connect to U, V and W as the inverter will be damaged.

(The phases do not need to be matched.)

Connect the motor to U, V and W.

The motor rotation direction will be counterclockwise (direction of the arrow, shown above) looking from the load shaft when the wires are connected as shown above and the forward rotation switch (signal) is turned on.

■ Connecting control signals

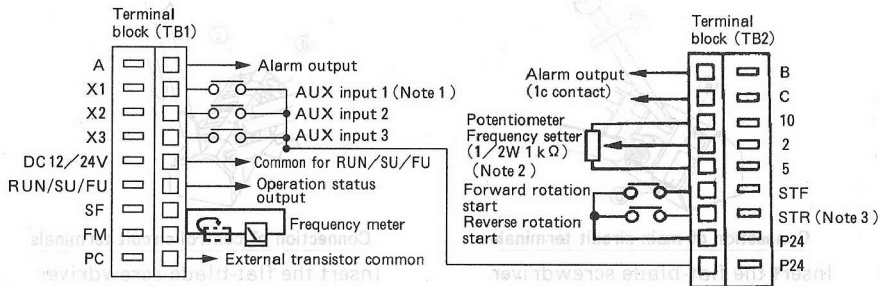

(Note 1) The function of the AUX input terminals (X1, X2, X3) is selected with the input terminal function selector [60] or allocation input terminals [61].

(Note 2) 2W1k Ω is recommended if the frequency setting is to be changed frequently.

(Note 3) The function of the STR terminal can be changed with the STR terminal function [62].

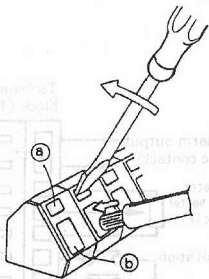

Connection of main circuit terminals

Insert the flat-blade screwdriver into the upper hole (a), and insert the power supply wire into (b) while pressing the screwdriver in the direction of the arrow. Remove the screwdriver when the wire has been inserted.

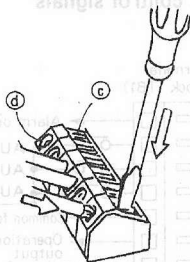

Connection of control circuit terminals

Insert the flat-blade screwdriver into the right hole (c), and insert the wire into (d) while pressing the screwdriver in the direction of the arrow. Remove screwdriver when the wire has been inserted.

(Note) Use a small flat-blade screwdriver (blade width 2.5 to 3mm).

■ Wire size and peeling length

● Applicable wire size for terminal block

	Main circuit (Note 1)	Control circuit
Wire size	Solid wire : 2 mm ² Strand : 2 mm ²	Solid wire : ϕ 0.4 to ϕ 1.0 mm Strand : 0.3 to 0.75 mm ²
Wire sheath peeling length	5 to 6 mm	8 to 10 mm

All wires are inserted into the terminal block excluding the grounding terminal.

Connected with rod terminals* or with only the wire instead of using crimp terminals.

(When using strands, make sure that the strands do not loosen to avoid a short circuit.)

Use a crimp terminal for only the grounding terminal.

Details to be checked in wiring planning

- (1) If a power failure occurs and the start signal (start switch) is retained, the inverter will automatically resume operation when the power is restored.
If the machine must be prevented from restarting with power restoration, install a magnetic contactor MC on the primary side of the inverter, and design a sequence to prevent the start signal from turning ON.
- (2) Use two contacts in parallel or a twin contact to prevent an imperfect contact for the input signal of the control circuit.
- (3) Do not input a voltage on the contact input terminal (STF, etc.) of the control circuit.
- (4) Do not apply the voltage directly onto the alarm output signal terminal (B, C). Pass the voltage through a relay coil or ramp.
- (5) When directly connecting the open collector output from a sequence controller to the inverter input terminal, make sure that a backflow current does not occur.

Use of PC terminal

When the external power common for transistor output is connected to this terminal, malfunctions caused by a backflow currents can be prevented.

<Correct connection>

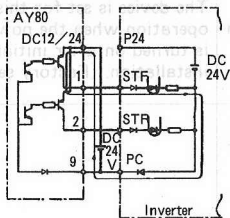

<Incorrect connection>

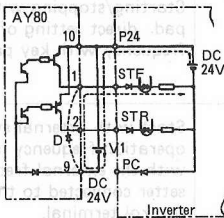

(Note) A DC24V power supply is required for the AY80 type unit.

Use the following countermeasures to prevent a backflow current when not using the PC terminal.

Countermeasures

- (1) Insert a diode to prevent the backflow current.
- (2) Use an all-point isolated type output unit.
- (3) The external power supply voltage must be higher than the inverter's control power supply.
- (4) Use a PC terminal (external transistor common).

⚠ [CAUTION] REMOVAL OF COVER WHEN UNIT IS POWERED GIVES ACCESS TO HIGH VOLTAGES. PLEASE ISOLATE INVERTER FROM POWER BEFORE PERFORMING ANY ADJUSTMENTS TO WIRING, ETC. WAIT AT LEAST 5 MINUTES AFTER ISOLATION BEFORE REMOVING FRONT COVER.

5. OPERATION

■ Operation methods

The following operation methods can be used. Select the method according to the application and operation specifications.

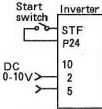
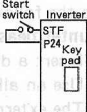
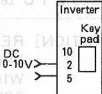
Operation method	Details	Remarks
Operation with key pad	Starting/stopping with key pad, direct setting of operation frequency with key pad.	The device is set for this operation when the power is turned on after initial installation. (Factory setting) 
Operation with external input signal	Start with external switch and operation frequency is adjusted with the external frequency setter connected to the inverter control terminal.	
Combined use of Operation with external input signals and key pad. (Refer to Pr.79)	Start with external switch and setting of operation frequency with key pad.	The external frequency setter and key pad RUN key are not accepted. Stop key is only accepted when Pr.75 is set to 14. 
	Setting of operation frequency with external frequency setter, starting/stopping with key pad.	The external start switch does not function. 

Operation with key pad

The key pad operation (parameter No. 79 "1") is selected as the factory setting.

MODE Frequency setting mode is entered.

▲ ▼ Set frequency is changed.

SET Set frequency is fixed.

RUN Motor starts (forward rotation) (Note).

**STOP
RESET** Motor stops.

(Note)

To drive the motor in the reverse direction with the **RUN** key, short-circuit between STR and P24 on the terminal block, or set parameter No.78 to "2".

Operation with external input signal

- Set external operation mode (parameter No. 79 "2").
(Refer to the following explanation for the setting method.)
The start signals and frequency are input with external switches and frequency setting potentiometer.
The motor will operate when a signal is input into STF (forward rotation) or STR (reverse rotation) and the frequency setter is operated.

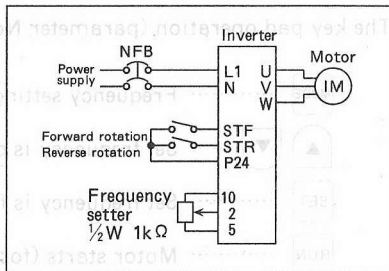

(Note 1)

The start signal self-holding function can be selected (for details see Pr.61)

(Note 2)

When potentiometer is used for the frequency setting input signal, set Pr.73 to 0.

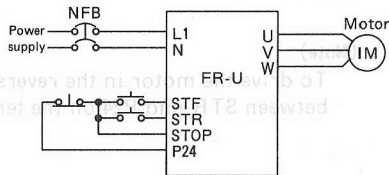

■ How to use the key pad

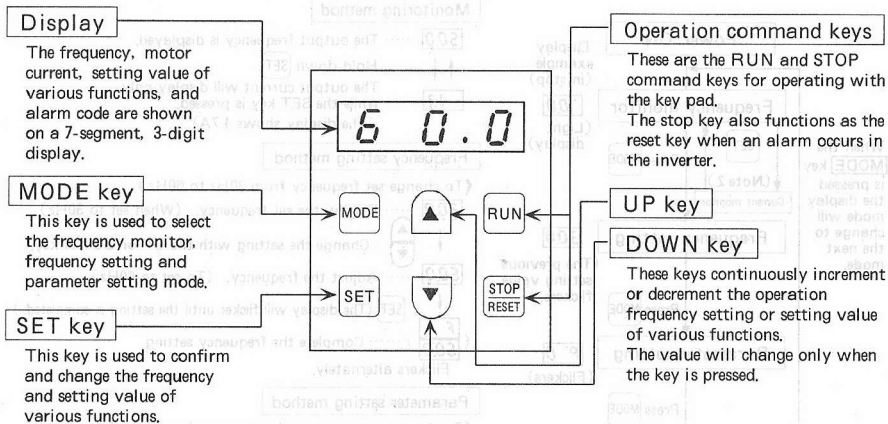

⚠ CAUTION : Never use any sharp or pointed object to depress the keys of the key pad.

This has been designed only for use with human fingers.

■ Monitor and parameter settings

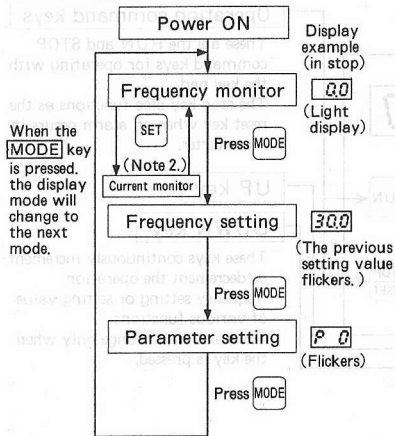

Monitoring method

50.0 The output frequency is displayed.



Hold down **SET**.

The output current will display only

while the SET key is pressed.
(The display shows 1.7A)

Frequency setting method

《To change set frequency from 30Hz to 60Hz》

30.0 Display the set frequency. (When set to 30Hz)



: Change the setting with the UP or DOWN key.

50.0 Adjust the frequency. (To set to 60Hz)



(The display will flicker until the setting is completed.)

F **50.0** Complete the frequency setting.

Flickers alternately.

Parameter setting method

《To change operation mode to external operation》

Display the parameter setting mode with the MODE key.

P 0 Parameter number.



: Change with the UP or DOWN key. (Note 1.)

P79 Set the parameter number.
(To set to operation mode)

(Note)

- 1) The parameter numbers will display in order with each press of the UP or DOWN keys.
(PO will display if the UP key is pressed when CLR is displayed.)
- 2) The current monitor displays only when the SET key is pressed in the frequency monitor mode.

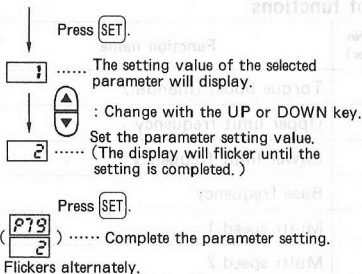

- When alarm (Er 1 to 3) is displayed
(The alarm can be canceled by pressing the mode key. The error will not be canceled when RESET is pressed.)

Alarm display	Type	Details
Er 1	Write prohibit alarm	Writing was attempted during the pr.77 "1" state (write prohibit)
Er 2	Write alarm during operation	Pr.79 was rewritten or all clear was executed during operation.
Er 3	Calibration error	The calibration value for C-2 and C-3 was too close. *

- * The calibration error will occur if the difference of the input voltage for the C-2 to C-3 calibration value is approximately 0.5V or less.

6. FUNCTIONS

■ List of functions

Function No. (parameter)	Function name	Setting range	Setting unit	Factory setting	User setting
0	Torque boost (manual)	0 to 15%	1 %	6 %	
1	Upper limit frequency	0 to 120 Hz	0.1 Hz	120 Hz	
2	Lower limit frequency	0 to 60 Hz	0.1 Hz	0 Hz	
3	Base frequency	50 to 120 Hz	0.1 Hz	50 Hz	
4	Multi-speed 1	0 to 120 Hz	0.1 Hz	50 Hz	
5	Multi-speed 2	0 to 120 Hz	0.1 Hz	30 Hz	
6	Multi-speed 3	0 to 120 Hz	0.1 Hz	10 Hz	
7	Acceleration time	0, 0.1 to 999 sec.	0.1 sec.	5.0 sec	
8	Deceleration time	0, 0.1 to 999 sec.	0.1 sec.	5.0 sec	
9	Electronic thermal relay	0 to 15A	0.1 A	Rated current	
10	PWM mode	0 to 15, ---	1	---	
11	DC dynamic braking operation time	0 to 10 sec.	0.1 sec.	0.5 sec.	
12	DC dynamic braking voltage	0 to 15%	1 %	8 %	
14	Applied motor selection	0, 10	1	0	
15	JOG frequency	0 to 120 Hz	0.1 Hz	5 Hz	

Function No. (parameter)	Function name	Setting range	Setting unit	Factory setting	User setting
16	JOG acceleration/deceleration time	0, 0.1 to 999 sec.	0.1 sec	0.5 sec	
17	External thermal relay input selection	0, 1	1	0	
19	Base frequency voltage	0 to 500V, ---	1 V	---	
20	Acceleration/deceleration reference frequency	1 to 120 Hz	0.1 Hz	50 Hz	
21	Frequency setting voltage bias	0 to 60 Hz	0.1 Hz	0 Hz	
22	Frequency setting voltage gain	0 to 120 Hz	0.1 Hz	50 Hz	
23	Stall prevention operation level	0 to 10	1	5	
24	Multi-speed 4	0 to 120Hz, ---	0.1 Hz	---	
25	Multi-speed 5	0 to 120Hz, ---	0.1 Hz	---	
26	Multi-speed 6	0 to 120Hz, ---	0.1 Hz	---	
27	Multi-speed 7	0 to 120Hz, ---	0.1 Hz	---	
37	Speed display	0, 0.1 to 999	0.1	0	
42	Up-to-frequency sensitivity	1 to 100%	1 %	10%	
43	Output frequency detection	1 to 120 Hz	0.1 Hz	6 Hz	
44	Output frequency detection during reverse rotation	1 to 120Hz, ---	0.1 Hz	---	

Function No. (parameter)	Function name	Setting range	Setting unit	Factory setting	User setting
46	No.2 acceleration/deceleration time	0, 0.1 to 999 sec., ---	0.1 sec.	---	
47	No.2 deceleration time	0, 0.1 to 999 sec., ---	0.1 sec.	---	
48	No.2 torque boost	0 to 15%, ---	1 %	---	
49	No.2 V/F (Base frequency)	50 to 120 Hz, ---	0.1 Hz	---	
50	Retry selection	0, 1, 2, 3	1	0	
51	No. of retries at alarm	0, 1 to 10, 101 to 110	1	0	
52	Retry execution wait time	0 to 360 sec.	0.1sec.	1 sec.	
53	No. of retry execution time display clear	0	0	0	
55	Frequency monitor reference	0 to 120 Hz	0.1 Hz	50 Hz	
56	Current monitor reference	0 to 200%	1 %	150%	
59	Remote setting function selection	0, 1	1	0	
60	Input terminal function selection	0 to 8	1	0	
61	Input terminal allocation	111 to 999 ---	1	---	
62	STR terminal function	0 to 10, ---	1	---	
70	FM output terminal function selection	0, 1	1	0	
71	Tone selection	0, 1	1	0	

Function No. (parameter)	Function name	Setting range	Setting unit	Factory setting	User setting
72	PWM carrier frequency	2.3 to 14.5 kHz	0.1 kHz	7.0 kHz	
73	Terminal 2 0-5V or 0-10V selection	0, 1	1	1	
75	Stop key function	0, 14	1	14	
76	Output signal selection	0, 1, 2	1	0	
77	Write prohibit selection	0, 1	1	0	
78	Reverse rotation prevention selection	0, 1, 2	1	0	
79	Operation mode selection	1, 2, 3, 4	1	1	
80	Multi speed 8	0 to 120Hz, ---	0.1Hz	---	
81	Multi speed 9	0 to 120Hz, ---	0.1Hz	---	
82	Multi speed 10	0 to 120Hz, ---	0.1Hz	---	
83	Multi speed 11	0 to 120Hz, ---	0.1Hz	---	
84	Multi speed 12	0 to 120Hz, ---	0.1Hz	---	
85	Multi speed 13	0 to 120Hz, ---	0.1Hz	---	
86	Multi speed 14	0 to 120Hz, ---	0.1Hz	---	
87	Multi speed 15	0 to 120Hz, ---	0.1Hz	---	
90	Ground fault detection	0, 1	1	1	
91	Frequency jump 1A	0 to 120Hz, ---	0.1Hz	---	

Function No. (parameter)	Function name	Setting range	Setting unit	Factory setting	User setting
92	Frequency jump 1B	0 to 120Hz, ---	0.1Hz	---	
93	Frequency jump 2A	0 to 120Hz, ---	0.1Hz	---	
94	Frequency jump 2B	0 to 120Hz, ---	0.1Hz	---	
95	Frequency jump 3A	0 to 120Hz, ---	0.1Hz	---	
96	Frequency jump 3B	0 to 120Hz, ---	0.1Hz	---	
CLr	Parameter clear	0, 1, 2	1	0	
C-1	Frequency meter scale calibration	—	—	—	
C-2	Frequency setting bias calibration	0 to 60 Hz	0.1 Hz	0 Hz	
C-3	Frequency setting gain calibration	0 to 120 Hz	0.1 Hz	50 Hz	

(Note)

1. The factory setting for Pr.79 operation mode selection is "1" (key pad mode).
2. The reset key on the key pad is accepted only during an alarm stop.
3. All parameters, excluding Pr.79, Pr.60 and Pr.CLr parameter clear, can be written during operation. (When Pr.77 = 0)
Writing is invalid when Pr.77 = 1, except for Pr.77.
4. The setting value "----" indicates "no function operation".
5. Pr.72 can be read and written when "----" is set in Pr.10.

■ Explanation of functions

● Torque boost (manual) 0

Low frequency motor torque can be adjusted to the load.

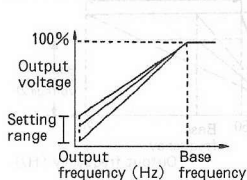

(Note)

If the setting value is too large, the overcurrent protective function may activate. The setting value can be adjusted while confirming the motor current with the monitor function. The No.2 torque boost is valid when terminals RT-P24³⁾ close if the No.2 acceleration/deceleration time Pr.46 is set.

[Factory setting]

Torque boost (manual) 6 %

No.2 torque boost (manual) - - -

● Upper limit frequency 1

The upper and lower limit clamps of the output frequency can be set.

[Factory setting]

- Upper limit frequency 120Hz
- Lower limit frequency 0 Hz

● Lower limit frequency 2

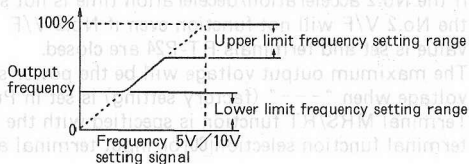

● V/F (base frequency) **3**

● Base frequency voltage **19**

● No.2 V/F (base frequency) **49**

The base frequency (reference frequency at motor rated power) can be set between 50 and 120Hz according to the motor rating.

The No.2 V/F is valid when terminals RT-P24³⁾ close if the No.2 acceleration/deceleration time Pr.46 is set.¹⁾

[Factory setting]

V/F (base frequency) 50Hz

Base frequency voltage ---

No.2 V/F (**49**) ---

(Note)

- 1) If the No.2 acceleration/deceleration time is not set, the No.2 V/F will not function even if No.2 V/F value is set and terminals RT-P24 are closed.
- 2) The maximum output voltage will be the power supply voltage when "---" (factory setting) is set in Pr.19.
- 3) Terminal MRS/RT function is specified with the input terminal function selection **60** or input terminal allocation **61**.

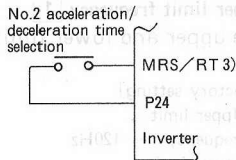
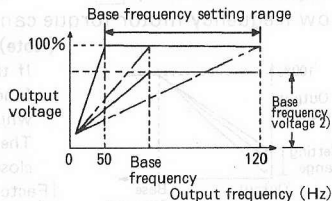

- Multi-speed 1

4

- Multi-speed 2

5

- Multi-speed 3

6

- Multi-speed 4

24

- Multi-speed 5

25

- Multi-speed 6

26

- Multi-speed 7

27

- Multi-speed 8

80

- Multi-speed 9

81

- Multi-speed 10

82

- Multi-speed 11

83

- Multi-speed 12

84

- Multi-speed 13

85

- Multi-speed 14

86

- Multi-speed 15

87

(Note)

Each speed can be selected (between terminals RH-P24, RM-P24, RL-P24 and REX-P24) by changing the contact signal from an external switch. Each speed (frequency) can be set within 0 to 120Hz during the inverter (motor) operation.

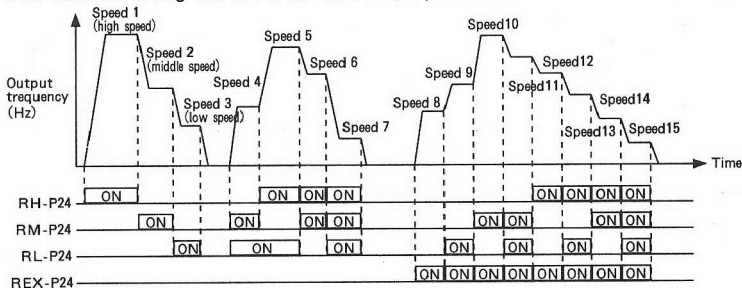

(Note)

1. The 4th to 15th speed cannot be selected if "---" is set (factory setting).
2. If two or three speeds are selected for the 3-speed setting, the low speed side frequency will be selected.
(Example) If high speed (RH) 40Hz and low speed (RL) 50Hz are set, when RH-P24 and RL-P24 turn ON simultaneously, 50Hz will be output.
3. If the multi-speed signal and external frequency signal are input, the multi-speed signal has priority.
4. The terminals RH (high), RM (medium) and RL (low) are selected with the input terminal function selection **60** or input terminal allocation **61**.
5. The terminal REX is selected with the STR input terminal selection **62**.
Reverse operation is not possible from external signal.

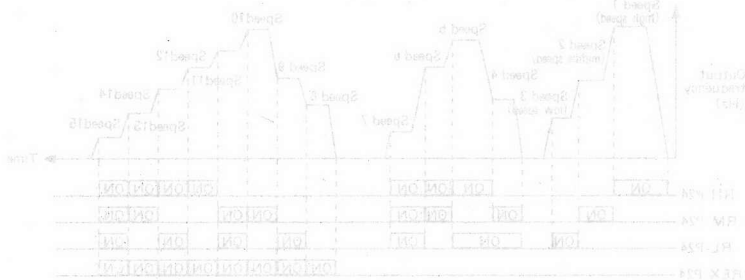

● Acceleration time **7**

● Deceleration time **8**

● Acceleration/deceleration reference frequency **20**

Pr.7 and 8 can be set between 0.1 and 999 seconds.

Acceleration time is the time taken for acceleration to the frequency (fm) set in acc./dec. reference frequency Pr.20.

If the acceleration/deceleration time is set to 0, the time will be 0.04 seconds.

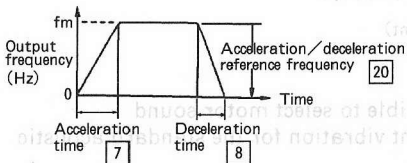

[Factory setting]

Acceleration time 5.0 sec.

Deceleration time 5.0 sec.

Acceleration/deceleration
reference frequency 50Hz

Carrier frequency	Setting value	Carrier frequency	Setting value	Carrier frequency	Setting value
1.8kHz	12	1.3kHz	6	0.7kHz	0
2.0kHz	13	1.4kHz	7	0.8kHz	1
2.1kHz	14	1.5kHz	8	0.9kHz	2
2.2kHz	15	1.6kHz	9	1.0kHz	3
Parameter 23 value	(Note 2)	1.7kHz	10	1.1kHz	4
		1.8kHz	11	1.2kHz	5

● Acceleration time **7**

● Deceleration time **8**

● Acceleration/deceleration reference frequency **20**

Pr.7 and 8 can be set between 0.1 and 999 seconds.

Acceleration time is the time taken for acceleration to the frequency (fm) set in acc./dec. reference frequency Pr.20.

If the acceleration/deceleration time is set to 0, the time will be 0.04 seconds.

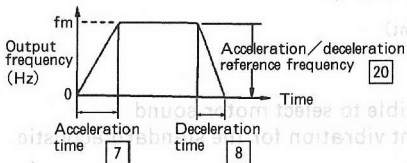

[Factory setting]

Acceleration time 5.0 sec.

Deceleration time 5.0 sec.

Acceleration/deceleration
reference frequency 50Hz

Carrier frequency	Setting value	Carrier frequency	Setting value	Carrier frequency	Setting value
1.8kHz	12	1.3kHz	6	0.7kHz	0
2.0kHz	13	1.4kHz	7	0.8kHz	1
2.1kHz	14	1.5kHz	8	0.9kHz	2
2.2kHz	15	1.6kHz	9	1.0kHz	3
Parameter 23 value	(Note 2)	1.7kHz	10	1.1kHz	4
		1.8kHz	11	1.2kHz	5

● **Electronic thermal relay** **9**

The setting value can be set as a current value (A) for the motor's overheating protection. Optimum protection characteristics, including a drop in the motor cooling performance at low speed operation, can be obtained. The motor protection function will not operate when set to 0 (A). (The output transistor protection function will operate.)

Set the motor rating current at 50Hz for the setting value.
Set to 0 (A) when using the external thermal relay.

[Factory setting] (Inverter rated output current)

● **PWM mode** **10**

By changing PWM mode setting, it is possible to select motor sound appropriate for load and to reduce resonant vibration for the standard acoustic noise model. Available in sixteen settings.

Setting value	Carrier frequency	Setting value	Carrier frequency	Setting value	Carrier frequency
0	0.7 kHz	6	1.3 kHz	12	1.9 kHz
1	0.8 kHz	7	1.4 kHz	13	2.0 kHz
2	0.9 kHz	8	1.5 kHz	14	2.1 kHz
3	1.0 kHz	9	1.6 kHz	15	2.2 kHz
4	1.1 kHz	10	1.7 kHz	(Note) 2.	Parameter 72 value
5	1.2 kHz	11	1.8 kHz		

[Factory setting] - - -

(Note)

1. The motor tone will increase in pitch when the setting value is increased.
2. The setting cannot be changed from "----" to "0 to 15" during operation. Always stop before making changes. Note that during operation the setting can be changed from "0 to 15".

● **DC dynamic braking operation time** **11**

By setting the DC dynamic braking torque (voltage) and the operation time, the accuracy in stop position can be adjusted matching the load.

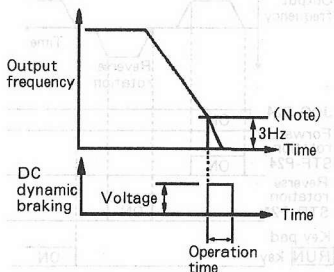

● **DC dynamic braking voltage** **12**

(Note)

The DC dynamic braking operation frequency is fixed to 3Hz.

Set the operation time to "0" when the DC dynamic braking is not required.

[Factory setting]

DC dynamic braking operation time ... 0.5 sec.

DC dynamic braking voltage 8 %

● **Applied motor selection** 14

When a Mitsubishi constant torque motor is used, set "10" for Pr.71. The thermal characteristics of the electronic thermal relay are set for constant torque motors with independent cooling.

Set Value	Characteristics of Electronic Thermal Relay
0	For general-purpose motors
10	For Mitsubishi constant torque motors

● **JOG frequency** 15

● **JOG acceleration/deceleration time** 16

Jogging operation will start and stop when the JOG mode is selected (short circuit between terminals JOG-P24), and the start signal (terminal STF or STR) is input.

(Note)

- JOG operation via key pad is also available.

When using the terminal JOG/OH for "JOG", set the external thermal relay input selection 17 to "0". If set to "1", the setting will be for the external thermal relay input selection.

[Factory setting]

- JOG frequency 5Hz
 JOG acceleration/deceleration time 0.5 sec.

(Note)

- Terminal JOG/OH is selected with the input terminal selection function 60 or input terminal allocation 61.

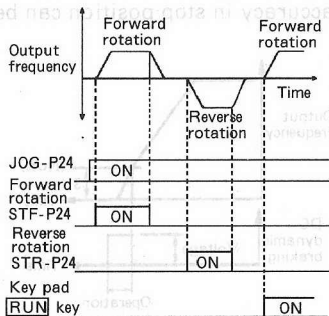

● External thermal relay input selection **17**

Set 1 in this parameter and set 0 in Pr.9 when external motor overload protector is used. Trip of an overload relay installed or motor thermostat, which opens on an overtemperature condition, stops drive operation.

(The alarm signal will also be output.)
Restarting will not be possible unless resetting is performed even if the thermal relay contact is restored. Therefore, this can be used as an emergency stop signal input from an external source. The inverter will stop when terminals JOG/OH-P24 open.

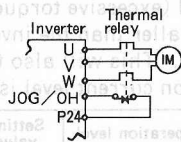

(Note)
When using terminal JOG/OH as an "external thermal relay input", set Pr.17 to "1".

(Note)

1. Select terminal JOG/OH with input terminal function selection **60**

● Frequency setting voltage bias **21**

● Frequency setting voltage gain **22**

The output frequency (ratio) for the frequency setting signal (DC 0 to 10V) can be set.

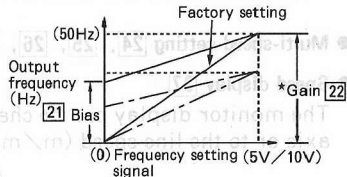

★When setting the bias and gain, the frequency setting signal need not be input.

● **Stall prevention operation level** **23**

An overload (excessive torque) can be prevented when driving a motor with a capacity smaller than the inverter by changing the stall prevention operation current level. This will also function during acceleration/deceleration. The operation current level is set with the following setting values (codes).

Setting value	Operation level	Setting value	Operation level	Setting value	Operation level
1	110%	5	150%	9	190%
2	120%	6	160%	10	200%
3	130%	7	170%	0	Stall prevention is not activated.
4	140%	8	180%		

[Factory setting] 5 (150%)

- The operation level % indicates the ratio to the inverter rated output current

● **Multi-speed setting** **24**, **25**, **26**, **27** → Refer to **Multi-speed setting** **4**

● **Speed display** **37**

The monitor display can be changed from frequency (Hz) to the speed of the load axis or to the line speed (m/min)

Example

<Line speed display>

- For 55m/min at 60Hz

Setting value → **5** **5**

* Input a speed of 60Hz.

The display may not match the actual speed due to the effect of motor slippage. When the load speed display has been selected, any function to be set in frequency (Hz) must still be set in frequency.

● Up-to-frequency sensitivity **42**

An output signal is available whenever the output frequency reaches a value selectable between $\pm 100\%$ of the operating frequency. (Setting from $\pm 1\%$ is possible)

[Factory setting] 10%

Setting value 0	Output frequency (Hz) display
Setting value 0.1 to 999	Display of load speed*

[Factory setting] 0

(Note)

Always set the speed at 60Hz. An input out of the range 0.1 to 999 is not possible.

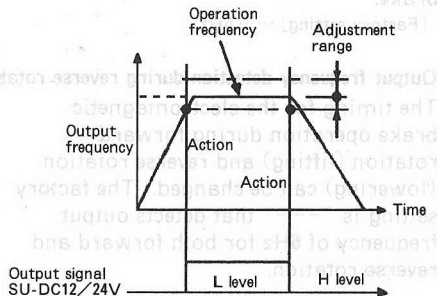

● **Output frequency detection** 43

The frequency to be detected can be set between 1 to 120Hz.

When the output frequency exceeds this frequency, the terminals FU-DC 12/24V will become the L level, and when lower, will become the H level. This can be used as a signal for actuation and release of a mechanical brake.

[Factory setting] 6Hz

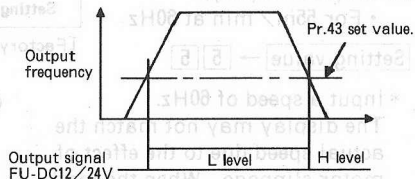

● **Output frequency detection during reverse rotation** 44

The timing for the electromagnetic brake operation during forward rotation (lifting) and reverse rotation (lowering) can be changed. The factory setting is "----" that detects output frequency of 6Hz for both forward and reverse rotation.

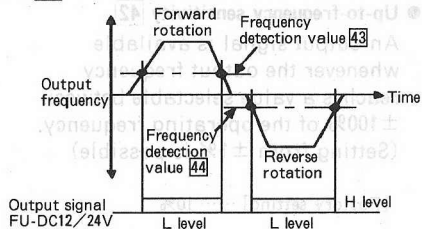

● No.2 acceleration/deceleration time **46**

The No.2 acceleration/deceleration time can be selected with an external contact signal. To do so, set Pr.46 and close terminals RT and P24. *1

When using the terminal MRS/RT for the "No.2 function", set the No.2 acceleration/deceleration time **46** within the range of "0 to 999". MRS (output stop function) will be applied if the setting is "----".

● No.2 deceleration time **47**

No.2 acceleration/
deceleration time
selection

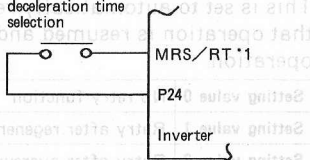

- To set deceleration time different from acceleration time, set parameter **46** as the acceleration time and **47** as the deceleration time.

(Note)

- *1 Terminal MRS/RT is selected with the input terminal function selection **60** or input terminal allocation **61**.
- *2 If function No. **47** is set to "----" (factory setting), the acceleration/deceleration time will be the same as that set in **46**.

[Factory setting]

No.2 acceleration/deceleration time "----" (terminal MRS/RT has output stop function)
 No.2 deceleration time "----"

- No.2 torque boost **48** → refer to Torque boost **1**
- No.2 V/F (Base frequency) **49** → refer to V/F (Base frequency) **3**
- Retry selection **50**

This is set to automatically reset the inverter when an inverter alarm occurs so that operation is resumed and continued. "OPT" will display during the retry operation.

Setting value 0	No retry function
Setting value 1	Retry after regenerative overvoltage trip (QVT) only
Setting value 2	Retry after overcurrent trip (OCT) only
Setting value 3	Retry after regenerative overvoltage trip (OVT) and overcurrent trip (OCT).

[Factory setting] 0

- No. of retries at alarm **51**

Set the number of retries and select the alarm signal output or not at alarm occurrence.

Setting value	Alarm signal output during alarm	No. of retries
0	—	No retry
1 to 10	Not available	1 to 10
101 to 110	Available	1 to 10

[Factory setting] 0

● **Retry execution wait time** **52**

The time before restarting after an inverter alarm occurs can be set.

[Factory setting] 1 sec.

● **No. of retry execution time display clear** **53**

The cumulative number of restart times made by retry can be read through reading this parameter and it can be cleared by setting 0.

[Factory setting] 0

(Note)

1. The monitor display after retrying will be the operation frequency.
2. If an alarm other than that set in Pr.50 (retry selection) occurs during retry waiting, an alarm will display and the retry will stop.
3. The inverter will automatically start operation after the time set in Pr.52 (retry execution wait time), and thus caution is required by the operators when using this function.



● Frequency monitor reference **55**

● Current monitor reference **56**

Terminal FM provides the frequency or current monitor function. Set the frequency or current value which is referenced for monitor in Pr.55 or Pr.56. (The frequency or current can be selected with Pr.70 (FM output terminal function selection).)

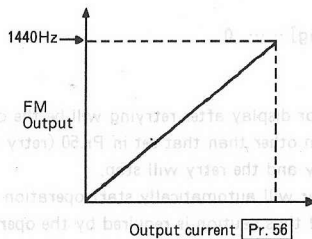
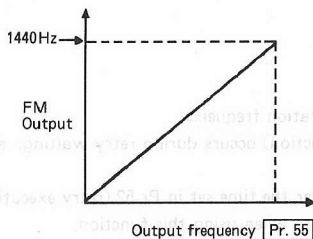

● Remote setting function selection **59**

The functions for terminals X1, X2 and X3 can be changed to the remote setting input function by setting 1 in Pr.60 (input terminal function selection). This allows the acceleration, deceleration and setting clear setting operations in the remote setting box FR-FK (optional) to be done just with parameter settings.

Pr. 59 setting value	Operation description	
	Remote setting function	Frequency setting value storage function (Note)
0	∨	∨
1	∨	—

— : No function ∨ : Function available

(Note)

If the terminals of acceleration-P24 and deceleration-P24 are left open for approximately one minute or longer or STF/STR-P24 is switched off or STOP key is pressed, the operation frequency setting value of that point will be registered in the memory. Operation will restart with that setting value even if the power supply is turned off and on once.

Connection

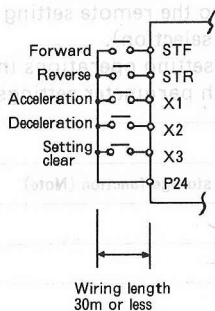

Example of operation

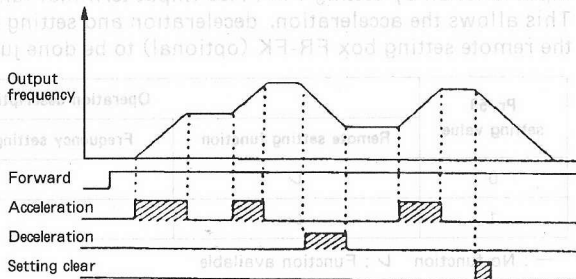

(Note)

The frequency setting value up/down times with the acc./dec. operation are set in Pr.46 (No.2 acceleration/deceleration time) and Pr.47 (No.2 deceleration time), but the output frequency acc./dec. times in Pr.7 and Pr.8. Therefore, the actual acc./dec. times become the longer setting values respectively.

● Input terminal function selection **60**

The functions of terminals (X1, X2, X3) can be group selected from the following nine types, for individual terminal function selection refer to **61**.

Terminal	Setting value								
	0	1	2	3	4	5	6	7	8
X1	RH	Acceleration	RES	RH	RH	RH	RH	RH	RH
X2	RM	Deceleration	MRS/RT	RM	RM	RM	MRS/RT	JOG/OH	MRS/RT
X3	RL	CLR	JOG/OH	JOG/OH	MRS/RT	RES	RES	RES	JOG/OH
	Multi speed	Remote setting							

[Factory setting] 0

(Note)

This parameter cannot be written during operation (writing is possible only when stopped).

Refer to the following page for the functions selected with the X1, X2 and X3 input terminals.

● List of function selections

Pr. 60	Mode	X1	X2	X3	Function	Related parameters
0	Multi-speed mode	OFF	OFF	OFF	Frequency reference 0 to 5V/10V	Pr.73
		ON	OFF	OFF	Multi-speed 1	Pr. 4
		OFF	ON	OFF	Multi-speed 2	Pr. 5
		OFF	OFF	ON	Multi-speed 3	Pr. 6
		OFF	ON	ON	Multi-speed 4	Pr.24
		ON	OFF	ON	Multi-speed 5	Pr.25
		ON	ON	OFF	Multi-speed 6	Pr.26
		ON	ON	ON	Multi-speed 7	Pr.27
1	Remote setting mode	OFF	OFF	OFF	0 to 5V/10V input setting	Pr.73
		ON	OFF	OFF	Frequency rise	—
		OFF	ON	OFF	Frequency lower	—
		OFF	OFF	ON	Frequency setting clear	—
		OFF	ON	ON	Frequency setting clear	— (Note)
		ON	OFF	ON	Frequency setting clear	—
		ON	ON	OFF	No operation	—
		ON	ON	ON	Frequency setting clear	—
2	RES	OFF	OFF	OFF	0 to 5V/10V input setting	—
	MRS/RT	ON	OFF	OFF	RES	—
	JOG/OH mode	OFF	ON	OFF	MRS/RT	Pr.46

Pr. 60	Mode	X1	X2	X3	Function	Related parameters
2	RES • MRS/RT • JOG/OH mode	OFF	OFF	ON	JOG/OH	Pr.17
		OFF	ON	ON	MRS/RT, JOG/OH	Pr.17, Pr.46
		ON	OFF	ON	RES	—
		ON	ON	OFF	RES	—
		ON	ON	ON	RES	—
3	JOG/OH • Multi-speed mode	OFF	OFF	OFF	0 to 5V/10V input setting	Pr.73
		ON	OFF	OFF	Multi-speed 3	Pr. 4
		OFF	ON	OFF	Multi-speed 2	Pr. 5
		OFF	OFF	ON	JOG/OH	Pr.17
		OFF	ON	ON	JOG/OH	Pr.17
		ON	OFF	ON	JOG/OH	Pr.17
		ON	ON	OFF	Multi-speed 6	Pr.26
		ON	ON	ON	JOG/OH	Pr.17
4	MRS/RT • Multi-speed mode	OFF	OFF	OFF	0 to 5V/10V input setting	Pr.73
		ON	OFF	OFF	Multi-speed 3	Pr. 4
		OFF	ON	OFF	Multi-speed 2	Pr. 5
		OFF	OFF	ON	MRS/RT	Pr.46
		OFF	ON	ON	MRS or middle speed, RT	Pr. 5, Pr.46
		ON	OFF	ON	MRS or high speed, RT	Pr. 4, Pr.46
		ON	ON	OFF	Multi-speed 6	Pr.26
		ON	ON	ON	MRS or 6th speed, RT	Pr.26, Pr.46

Pr. 60	Mode	X1	X2	X3	Function	Related parameters
5	RES • Multi-speed mode	OFF	OFF	OFF	0 to 5V/10V input setting	Pr.73
		ON	OFF	OFF	Multi-speed 3	Pr. 4
		OFF	ON	OFF	Multi-speed 2	Pr. 5
		OFF	OFF	ON	RES	—
		OFF	ON	ON	RES	—
		ON	OFF	ON	RES	—
		ON	ON	OFF	Multi-speed 6	Pr.26
6	MRS/RT • RES • Multi-speed mode	OFF	OFF	OFF	0 to 5V/10V input setting	Pr.73
		ON	OFF	OFF	Multi-speed 3	Pr. 4
		OFF	ON	OFF	MRS/RT	Pr.46
		OFF	OFF	ON	RES	—
		OFF	ON	ON	RES	—
		ON	OFF	ON	RES	—
		ON	ON	OFF	MRS or high speed, RT	Pr. 4, Pr.46
		ON	ON	ON	RES	—

Pr. 60	Mode	X1	X2	X3	Function	Related parameters
7	JOG/OH • RES • Multi-speed mode	OFF	OFF	OFF	0 to 5V/10V input setting	Pr.73
		ON	OFF	OFF	Multi-speed 3	Pr. 4
		OFF	ON	OFF	JOG/OH	Pr.17
		OFF	OFF	ON	RES	--
		OFF	ON	ON	RES	—
		ON	OFF	ON	RES	—
		ON	ON	OFF	JOG/OH	Pr.17
		ON	ON	ON	RES	—
8	MRS/RT • JOG/OH • Multi-speed mode	OFF	OFF	OFF	0 to 5V/10V input setting	Pr.73
		ON	OFF	OFF	Multi-speed 3	Pr. 4
		OFF	ON	OFF	MRS/RT	Pr.46
		OFF	OFF	ON	JOG/OH	Pr.17
		OFF	ON	ON	MRS/RT, JOG/OH	Pr.46, Pr.17
		ON	OFF	ON	JOG/OH	Pr.17
		ON	ON	OFF	MRS or high speed, RT	Pr. 4, Pr.46
		ON	ON	ON	MRS/RT, JOG/OH	Pr.46, Pr.17

(Note) ON : Short with terminal P24.

OFF : Open

(When function OH has been selected (1 in Pr.17), ON indicates open.)

● Allocation input terminals **61**

The function of the input to terminals X 1, X 2, X 3 can be allocated from the 8 functions in the table below.

Pr. No	Setting range	Setting Unit	Factory Setting	Function
61	111 to 999 -----	1	---	<p>----- : The functions are as Pr.60 setting</p> <p>1 : RH</p> <p>2 : RM</p> <p>3 : RL</p> <p>4 : OH</p> <p>5 : STOP</p> <p>6 : MRS</p> <p>7 : RT</p> <p>9 : JOG</p>

Setting is made by a 3 digit number set in Pr61, each digit represents the function to be allocated to individual terminals. (note1)

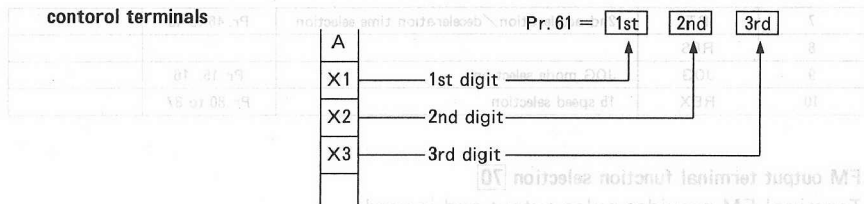

Note 1) When two or more digits of Pr.61 are set to the same number, the function is activated by turning on one of them.

Note 2) When a value "0 to 999" is set in Pr.61, the set values of Pr.60 is ignored.

● **STR terminal function** 62

The function of the input to terminal STR can be allocated from the 8 functions in the table below.

Setting value	Function code	Function	Related Pr.	Remarks
---	STR	Reverse rotation start		Factory setting
1	RH	Multi-speed 3	Pr. 4	
2	RM	Multi-speed 2	Pr. 5	
3	RL	Multi-speed 1	Pr. 6	
4	OH	External thermal relay input		
5	STOP	Start signal self-holding selection		
6	MRS	Output stop		

7	RT	2nd acceleration/deceleration time selection	Pr. 46 to 49
8	RES		
9	JOG	JOG mode selection	Pr. 15, 16
10	REX	15 speed selection	Pr. 80 to 87

● FM output terminal function selection **70**

Terminal FM provides pulse output and is used to connect an indicator that monitors frequency or current. The frequency or current can be selected through this parameter.

Setting value 0	Output frequency
Setting value 1	Motor current (output current)

[Factory setting] 0

(Note)

When the frequency has been selected, terminal FM output can be adjusted with Pr.55, when the current has been selected, it can be adjusted with Pr.56.

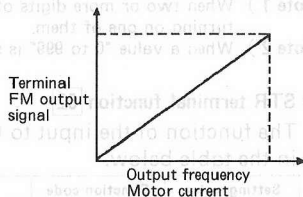

● **Tone modulation selection** **71**

(This parameter is a function number for the low-acoustic noise series)

The tone control that changes the motor tone can be selected with the key pad.

Setting value	Tone selection
0	No tone control
1	Tone control

[Factory setting] 0

- The tone control changes the motor noise from a metallic tone to a composite sound that is easy to listen to.
- When the tone control is selected, the motor tone will be easy to listen to even with the same carrier frequency.
- The tone control is effective when the carrier frequency is low.

● **PWM carrier frequency** **72**

(This parameter is a function number for the low-acoustic noise series)

The PWM carrier frequency is 7.0 kHz but this frequency can be changed with Pr. 72 if necessary in relation to the load or motor resonance frequency.

(Note) If the PWM carrier frequency is lowered, the motor noise will increased, but the noise generated from the inverter and the leakage current will decrease.

(Refer to the precautions on page 62 when setting the PWM carrier frequency to a higher value.)

(Note)

This parameter can be read and written when the PWM mode Pr.10 setting is "----".

[Factory setting] 7.0 kHz

● **Terminal 2 0-5V or 0-10V selection** 73

It is possible to change the input specification (terminal 2) according to the frequency reference voltage signal.

Setting value	Input voltage at terminal 2
0	For 0 to 5 VDC input
1	For 0 to 10 VDC input

[Factory setting] 1

Note 1) To change the output frequency corresponding to the input of the maximum frequency command voltage, a value should be set for C-3 frequency setting gain calibration.

It is not necessary to input a command voltage. Refer to page 59 for alternative calibration procedure.

The acceleration/deceleration time is not influenced by a change in Pr.73 setting since it defines the gradient up to the acceleration/deceleration reference frequency set in Pr.20.

2) Set "0" for Pr.73 when the inverter is operated with a potentiometer. (1 or 2W 2k Ω)

● Stop key function 75

When "stop key" is pressed in external operation mode, motor is decelerated to a stop.

Setting value	Stop key function
0	The stop key only functions in PU op or councinel mode
14	When stop key is pressed in any operation mode, motor stops.

[Factory setting] 14

Note 1) To restart after "stop key stopping" in ext mode.

- ① Turn off the start signal (STF/STR) after the motor has stopped.
- ② Press the "SET" key.
- ③ Turn on the start signal (STF/STR).

Note 2) When motor is stoped by using the stop key in external operation mode, "E 0" is displyed.

● Output signal selection 76

The inveter running, up-to-frequency or frequency detection signal can be selected for the open collector output signal (terminal RUN/SU/FU).

Setting value 0	Inverter running (RUN)
Setting value 1	Up-to-frequency (SU)
Setting value 2	Frequency detection signal (FU)

[Factory setting] 0

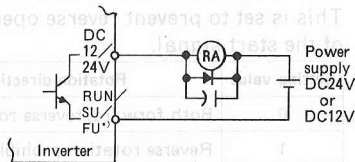

*)
(Note) The inverter will be damaged if the voltage application direction is mistaken. Also, take care to prevent mis-wiring such as of the diode connection direction.

● **Parameter write prohibit selection** **77**

Writing-in of every function with the key pad can be prohibited.

Setting value	Write prohibition function
0	Parameter writing permitted (during operation and stop)
1	Parameter write prohibited (Note)

[Factory setting] 0

(Note)

Parameter No. **77** can be written in. Er1 will display when writing of other parameters is attempted. (Release the error display with the MODE key.)

● **Reverse rotation prevention selection** **78**

This is set to prevent reverse operation from trouble caused by mistaken input of the start signal.

Setting value	Rotation direction
0	Both forward/reverse rotation
1	Reverse rotation prohibited
2	Forward rotation prohibited (Note)

(Note)

The inverter will drive the motor in reverse with the RUN key when set to "2".

[Factory setting] 0

Both key pad operation and external operation are valid.

● Operation mode selection **79**

The inverter operation modes include operation with external signals and operation with key pad. Operation can be limited to one mode or can be carried out with both modes.

Setting value 1	Operation only with key pad
Setting value 2	Operation only with external signals
Setting value 3	Operation frequency ... Set with key pad (direct setting or ▲▼ keys) Start signal ... External signal input (STF, STR terminals)
Setting value 4	Operation frequency ... External signal input (DC0 to 5V/10V between terminals 2-5) Start signal ... Input with key pad (RUN key) (Note) 4.

[Factory setting] 1

(Note)

1. This parameter cannot be rewritten during operation. Er2 will display if writing is attempted.
2. Setting values 3 and 4 are set to use the external signals and key pad operation for the operation frequency setting and start signals.
3. When set to 3, the operating frequency is set via key pad and analog signal input is ignored.
4. When set to 4, the operating frequency is set via analog signal input, multi-speed setting or JOG frequency setting.

● Multi-speed setting **80** to **87** → Refer to Multi-speed setting **4**

● Ground fault detection 90

It is possible to detect an output side earthing/grounding fault when the inverter starts operation. The inverter shuts off the output, displays E. GF and outputs the alarm signal when a earthing/grounding fault is detected.

[Factory setting] 1

Setting value	Details
0	No ground fault protection
1	Ground fault protection on

● Frequency jump 1A 91

● Frequency jump 1B 92

● Frequency jump 2A 93

● Frequency jump 2B 94

● Frequency jump 3A 95

● Frequency jump 3B 96

Resonance can occur at certain speeds in some applications when a motor is driven by an inverter. To avoid this resonance upto three jump positions can be set. by defining the upper and lower frequency limits in 91 to 96.

The 1A, 2A or 3A setting value becomes the jumping point, the inverter will run at that frequency while in the frequency jump range.

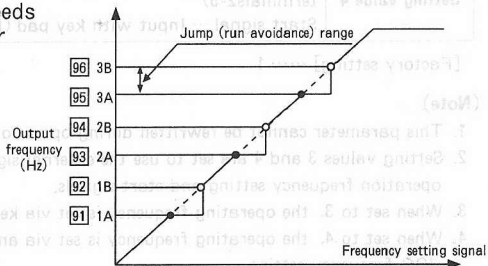

Note) 1 : Frequency jump will not function if 9999 (default value) is set.

2 : During acceleration and deceleration, the frequency in the setting range will be passed through.

● **Parameter clear/calibration** **CLr**

The parameter-all-clear or frequency setting signal calibration mode can be selected. The parameter-clear cannot be executed during operation, and Er2 will display.

Setting value	Details
0	Not executed.
1	Parameters are all cleared (initialized). *
2	Frequency setting signal calibration mode is selected.

* Parameter No. **77**, **21**, **22** cannot be cleared.

- The following adjustment can be performed by selecting the calibration mode (setting value 2).
(Refer to page 61 for details.)

- C-1** Display:Frequency meter scale calibration
- C-2** Display:Frequency setting bias calibration (Pr.21 will be rewritten simultaneously.)
- C-3** Display:Frequency setting gain calibration (Pr.22 will be rewritten simultaneously.)

If the difference of the input voltages for the bias and gain calibration is less than 0.5V, the calibration error will occur (Er3 will display).

● **Frequency meter scale calibration** **C-1**

Allows a meter connected to FM to be calibrated through this parameter, without a calibration potentiometer. Using Pr. C-1, press ▲ or ▼ key to vary pulse train frequency. Then average of output voltage changes, and the meter is calibrated.

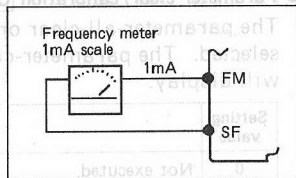

(Note)

1. Terminal FM output is a 1440Hz at output frequency of 60Hz as the factory setting.
2. If terminal FM-SF is measured with a tester, approx. 5V (average value) will be indicated at the max. Output frequency. (When indicator is not connected.)

FM terminal pulse output specifications

Connection of a digital counter allows for digital indication of frequency (Hz) or speed (m/min.).

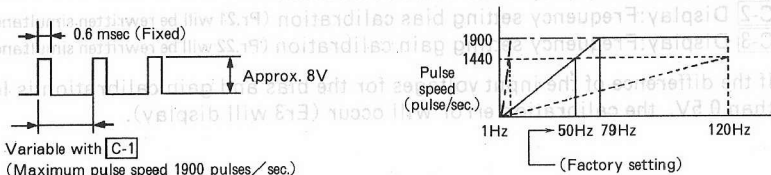

● Frequency setting bias calibration **C-2**

● Frequency setting gain calibration **C-3**

Allows the output frequency to be set in relation to the frequency setting signal (DC 0 to 5V or 0 to 10V).

<Bias>

The output frequency for the setting signal input between terminals 2-5 will be set.

<Gain>

The output frequency for the setting signal input between terminals 2-5 will be set. If the input signal is 0V, it is judged to be 5V (10V) input.

(Note)

- When this C-2 or C-3 is specified, value set for "frequency setting voltage bias" (function No. 21) or "frequency setting voltage gain" (function No.22) will be automatically rewritten.

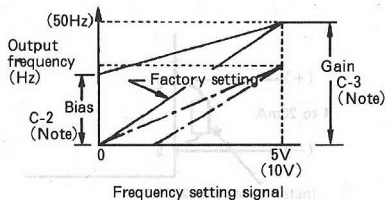

Remarks To set frequency with current input (4 to 20mA)

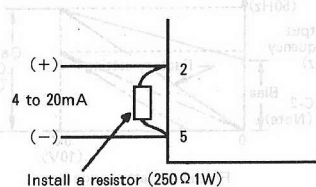

1. Place a resistor between 2-5, and convert the current into a voltage. (4 to 20mA → 1 to 5V) Pr.73 set to "0".
2. Adjust C-2 (bias) as below.
(Pr.21 will be rewritten simultaneously.)

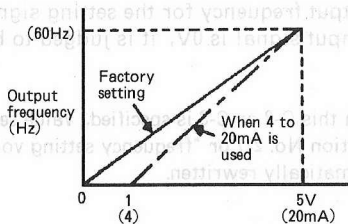

○ Example of parameter-all-clear/calibration operation

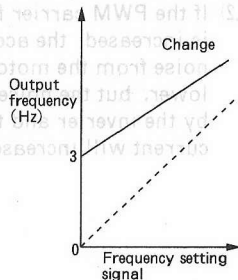
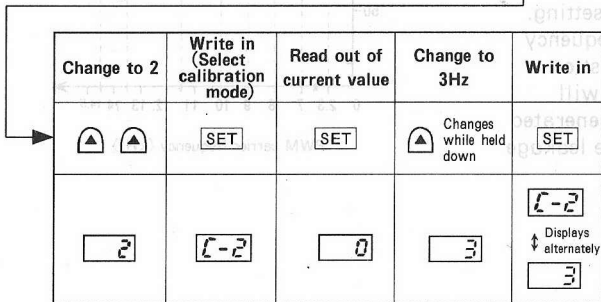
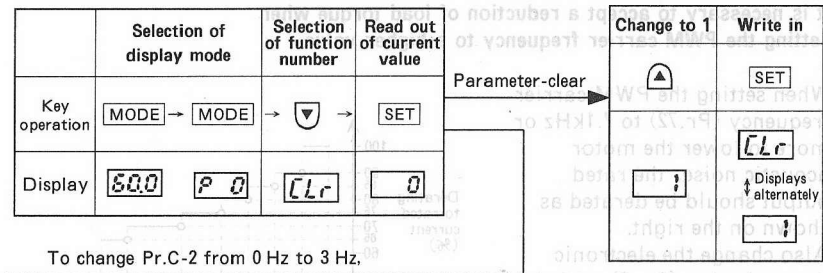

Precautions

1. It is necessary to accept a reduction of load torque when setting the PWM carrier frequency to a higher value.

- (1) When setting the PWM carrier frequency (Pr.72) to 7.1kHz or more to lower the motor acoustic noise, the rated output should be derated as shown on the right. Also change the electronic thermal relay (Pr. 9) setting.
- (2) If the PWM carrier frequency is increased, the acoustic noise from the motor will lower, but the noise generated by the inverter and the leakage current will increase.

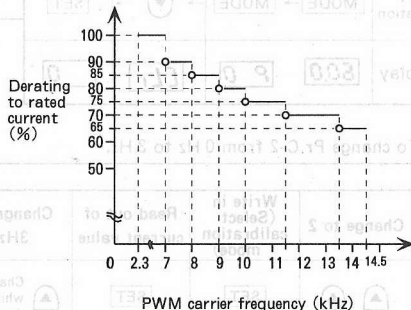

2. Noise

◆ Example of noise countermeasures

There is noise that enters from outside and causes the inverter to malfunction and that which is generated from the inverter and causes the peripheral equipment to malfunction. The inverter is designed so that it is not easily affected by noise, but as it is an electronic device which handles weak signals, the following general countermeasures will be required.

◆ General countermeasures

- Avoid laying the inverter's power cables (input/output) in parallel with the signal wires and avoid bundling the power cables and signal wires.
- Use twisted pair shield wires for the connection wires with the sensor and for the control signal wires. Connect the sheath of the shield wire to the common of the signal.
- Use one-point grounding for the inverter and motor, etc.

◆ Example of noise countermeasures

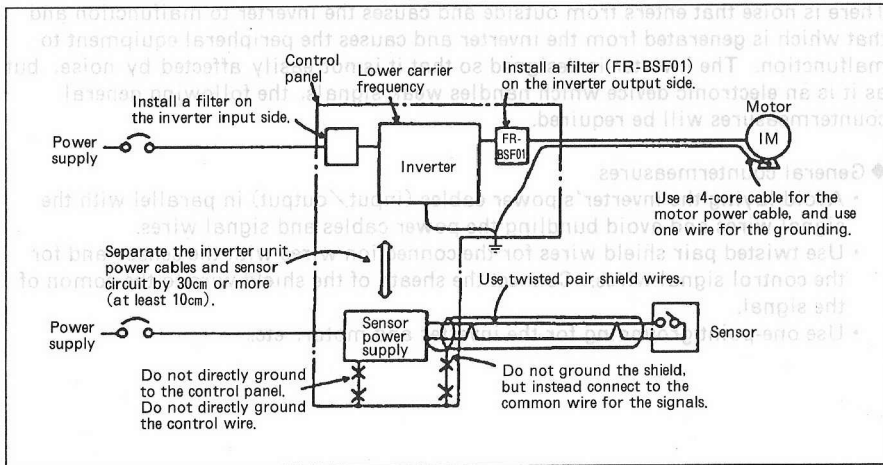

3. Leakage current

Leakage current will flow through stray capacity which exists between the ground and a cable, motor, etc. The value of the leakage current depends on the cable length, wiring method and inverter carrier frequency, and will increase when using a low-acoustic noise inverter, so use the following countermeasures.

(1) Leakage current to the ground

The leakage current will not affect only the inverter but may pass into other equipment through the grounding cables and may cause a leakage breaker or relay unnecessary trip.

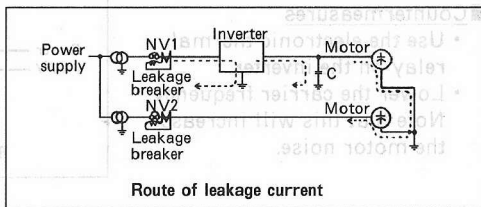

■ Countermeasures

- Lower the inverter's carrier frequency (Pr. 72).
Note that this will increase the motor acoustic noise.
- Use a leakage breaker that corresponds to high harmonics and surges (Mitsubishi New Super NV Series, etc.) for the inverter or other lines when using the low-acoustic noise model (with high carrier frequency).

(2) Leakage current across the line

The harmonics of leakage current which flows through stray capacity across the inverter output lines may cause an external thermal overload protector trip. When the cable length is long (50m or more), the ratio of leakage current to the motor's rated current becomes large, and trip is liable to occur.

■ Countermeasures

- Use the electronic thermal relay on the inverter.
- Lower the carrier frequency. Note that this will increase the motor noise.

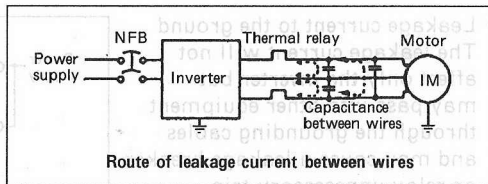

Against the trip due to leakage current, the preferred method of motor overload protection is a thermistor protection with temperature detectors in the motor or motor protection switch with bi-metal release, etc.

7. SPECIFICATIONS

■ Standard specifications

Model FR-U120S-N□-EC		0.2K	0.4K	0.75K
Applicable motor capacity (kW) *1		0.2	0.4	0.75
Output	Rated capacity (kVA) *2	0.6	1.0	1.7
	Rated output current (A)	1.4	2.4	4.1
	Overload current rating *3	150% 60 sec. 200% 0.5 sec. (reverse time characteristic)		
	Rated output voltage *4	3-phase 220 to 240V		
Power supply	Rated input AC voltage	Single-phase 220 to 240V 50/60Hz		
	Tolerable AC voltage fluctuation	198 to 264V 50/60Hz		
	Tolerable frequency fluctuation	± 5 %		
	Power supply capacity (kVA) *5	0.9	1.5	2.5
Protective structure		Semi-closed type (IP10)		
Cooling method		Self-cooling		
Weight (kg)		0.7	0.9	1.7

(Note)

- * 1. The maximum applicable capacity is for a Mitsubishi standard 4P motor. 6P motors drawn high current, so check the current rating carefully.
- * 2. The rated capacity is shown for an output voltage of 240V.
- * 3. The overload current value % shows the ratio to the inverter's rated output current.
- * 4. The output voltage cannot exceed the power supply voltage.
- * 5. The power capacity will differ according to the impedance on the power supply side (including reactor and power wires on input side). Prepare a power supply capacity higher than the noted value.

■ Common specifications

Control specifications	Control method		Sinusoidal wave PWM control
	Output frequency range		0.5 to 120Hz (starting frequency fixed at 0.5Hz)
	Frequency setting resolution	Digital input	0.1Hz (less than 100Hz), 1Hz (100Hz and more) with key pad operations
		Analog input	1/500 (0-10V) or 1/250 (0-5V) of maximum setting frequency
	Frequency stability	Digital input	Within $\pm 0.5\%$ of set output frequency (-10 to $+50^{\circ}\text{C}$) with key pad operations
		Analog input	Within $\pm 1\%$ of maximum output frequency ($25^{\circ}\text{C} \pm 10^{\circ}\text{C}$)
	Voltage/frequency characteristics		Base frequency between 50 and 120Hz selectable
	Torque boost		Manual torque boost 0 to 15% selectable
	Acceleration/deceleration characteristics		0, 0.1 to 999 sec. selectable (acceleration/deceleration set separately)
	Braking torque	Regenerative *6	0.2K...150% or more, 0.4K, 0.75K...100% or more,
DC injection		3Hz or less Operation time, operation voltage adjustable	
Stall prevention operation level		Operation current level (110 to 200%) selectable	
Operation specifications	Frequency setting signal		DC 0 to 5V or 0 to 10V
	Input signal	Starting signal	Forward/reverse rotation commanded separately
		Input signal selection (X1, X2, X3)	Select RH, RM, RL, JOG/OH, MRS/RT, RES, accelerations, deceleration and CLR from the combinations shown on page 43 or individually shown on page 48.
		STR terminal function	Select STR, RH, RM, RL, OH, STOP, MRS, RT, RES, JOG and REX shown on page 49.
Output signal	Alarm	1c contact output. Electric rating is shown on page 74.	

	Output signal	Operation status	Select from operating (RUN), frequency reached (SU) and frequency detection (FU)
		Monitor * 9	For analog (1mA full scale) or digital (1440Hz/60Hz) meter
Display	Key pad	Operation status	Output frequency, output current * 8, operation speed selectable
		Alarm	Alarm code when protective function has been activated.
Protection/warning function			Overcurrent shut down (during acceleration/deceleration/constant speed), regenerative overvoltage shut off, electronic thermal overload, stall prevention, earth fault over current (at start)
Environment	Ambient temperature		-10 to +50°C (with no freezing)
	Ambient humidity		90% RH or less (with no dew condensation)
	Storage temperature * 7		-20 to +65°C
	Atmosphere		Indoors with no corrosive or flammable gases, oil mist or dust
	Altitude/vibration		Less than 1000m above sea level, 5.9m/S ² (0.6G) or less

(Note)

- * 6. The braking torque shows the short time average deceleration torque when the motor without load is decelerated in the shortest time from 60Hz (changes due to motor's loss), and is not the continuous regenerative torque. For deceleration from a frequency that exceeds the base frequency, the average deceleration torque value will decrease.
A brake resistor is not built-in and cannot be externally installed.
- * 7. This is a short time temperature for during transportation, etc.
- * 8. The output current is displayed only while the SET key is being pressed.
- * 9. Select the monitor of either the output frequency or motor current via the key pad (function No.70).

Terminal wiring diagram

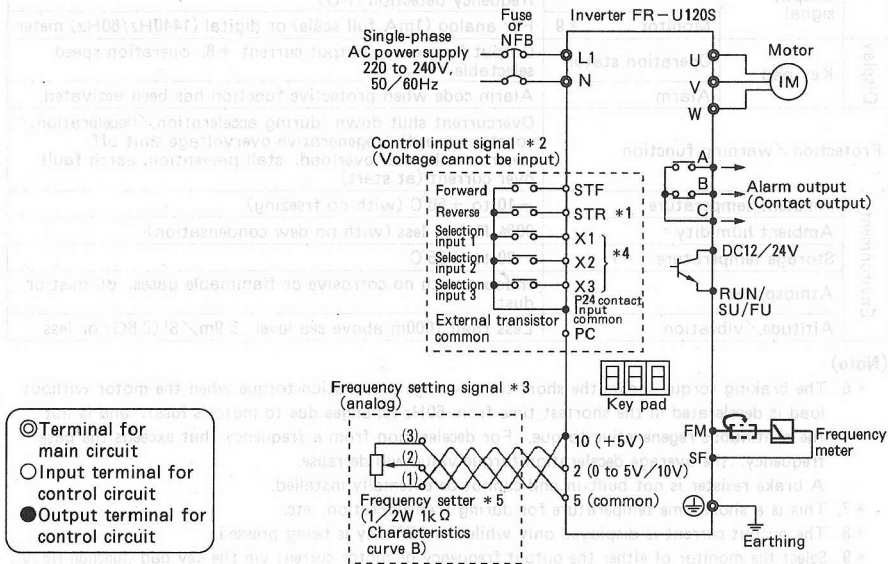

- * 1. Short-circuit between terminals STR-P24 to perform reverse rotation with key pad operation. When Pr.78 is set to "2" (forward rotation prohibited), the motor will rotate in the reverse direction with the key pad operation even if STR-P24 are not short circuited. (When Pr.79 is 1 or 4)

STR terminal function can be changed with Pr.62.

- * 2. Valid when parameter No.79 is set to "2" or "3" via key pad.
- * 3. Valid when parameter No.79 is set to "2" or "4" via key pad.
- * 4. Input terminals X1, X2 and X3 are selection input terminals, specified with Pr.60. and Pr. 61 (Refer to page 43, 48.)
- * 5. 2W1k Ω is recommended if the frequency setting is to be changed frequently.
- * 6. If the potentiometer is used for the frequency setting input signal, set Pr. 73 to 0. Frequency setting voltage gain must be adjust by Pr.22.

See Section 6 (page 59 to 61)

■ Explanation of terminal specifications

Terminal symbol		Terminal name	Details
Main circuit	L1, N	AC power input terminal	Connect to a commercial power supply.
	U, V, W	Inverter output terminal	Connect a 3-phase motor.
		Earthing terminal	Earth for inverter body. Earth this.
Control circuit (Input signal)	STF	Forward rotation starting terminal	Contact input terminal for the forward run command. The motor will forward rotate when STF-P24 are short circuited, and will stop when released.
	STR	Reverse rotation starting terminal	Contact input terminal for the reverse run command. The motor will reverse rotate when STR-P24 are short circuited, and will stop when released. The STR terminal function can be changed by changing the parameter No.62 setting. (Refer to page49 for the selection).
	P24	Contact input common terminal	Common terminal for the contact input signal.
	10	Power supply terminal for frequency setting	DC5V. Tolerable load current 10mA.
	2	Frequency setting terminal (Voltage signal)	Output frequency will be the maximum at DC 5V or 10V, and the input/output will be in proportion. Input resistance : 10kΩ Max. tolerable input voltage : 10V

Terminal symbol	Terminal name	Details
Control circuit (Input signal)	5	Frequency setting input common terminal Common terminal for the frequency setting signal. This is not insulated from the display meter connection terminal common SF.
	X1, X2, X3	AUX input terminal The terminal specifications will change according to the parameter No.60 and No.61 setting. (Refer to page 43, 48 for the selection). (The specification will be RH, RM, RL, JOG/OH, MRS/RT, RES, acceleration, deceleration or CLR.)
	PC	External transistor common terminal When connecting to the transistor output (open collector output) of a sequencer, etc., if the external power common for transistor output is connected to this terminal, malfunctions caused by backflow currents can be prevented. (Refer to page 13.)
	RH, RM, RL REX(Notes 1)	Multi-speed selection terminal A maximum of 15 speeds selectable with the combination of RH-P24, RM-P24, RL-P24 and REX-P24 short circuiting.
	JOG/OH (Note 1)	JOG mode selection or external thermal relay JOG operation is selected when terminals JOG-P24 turn ON, and jog operation starts with the start signal (STF or STR). The thermal relay contact input terminal can be selected for stopping the inverter by operating the externally connected thermal relay.
	MRS/RT (Note 1)	Output stop or No.2 acceleration/ deceleration time selection The inverter output will stop when MRS-P24 are short-circuited. This terminal is set with Pr.46 for the No.2 acceleration/deceleration time selection (RT). The No.2 acceleration/deceleration time can be selected by short-circuiting between RT-P24.

Terminal symbol	Terminal name	Details
Control circuit (Input signal)	RES (Note 1) Reset terminal	This is used to reset the hold state during operation of the protection circuit. Short-circuit between RES-P24 for 0.1sec. or longer, and then open. (Resetting is also possible with the RESET key on the key pad.)
	Acceleration, deceleration, CLR (Note 1) Remote setting terminal	These can provide remote operator control for the following functions. When terminals acceleration-P24 are short-circuited, the frequency will increase, and will decrease when terminals of deceleration-P24 are short-circuited. When CLR-P24 are short-circuited, the speed will return to the reference speed (frequency set with frequency setting signal or input from key pad.) The frequency increment/decrement speed is set with Pr.46 (acceleration) and Pr.47 (deceleration).
Control circuit (Output signal)	A, B, C Alarm output terminal	1c contact output that indicates that the inverter protection circuit has functioned and output has stopped. B-C opened, A-C closed during alarm B-C closed, A-C opened during normal operation Contact capacity DC30V 0.3A
	FM Display meter connection terminal	The output is set to be approximately 5V at 50Hz without display meter, and will be proportional to the output frequency. The output voltage has a pulse waveform, so a digital display meter can be connected. Pulse specifications : 8V (peak), 1440Hz/50Hz. (Refer to page 55. 56. 57)
	SF Display meter connection common terminal	Common to FM. This is not isolated from frequency setting input common 5.

Terminal symbol	Terminal name	Details
Control circuit (Output signal)	RUN SU FU	<p>Operation state output terminal</p> <p>One of the inverter operating (RUN), frequency reached (SU) or frequency detection (FU) output selectable.</p> <ul style="list-style-type: none"> • Inverter operating (RUN) is at L level when above the starting frequency, and is at H level when stopped or during DC braking. • Frequency reached (SU) is at L level when the output frequency reaches the set frequency, and is at H level when stopped or during acceleration/deceleration. • The frequency detection (FU) is at L level when the output frequency exceeds the set detection frequency, and is at H level when lower than the set frequency. <p>Open collector output tolerable load : DC24V 0.1A</p>
	DC12/ 24V	<p>Output common terminal</p> <p>Common terminal for RUN, SU, FU</p>

(Note)

- * 1 This terminal is selected with the Pr.60, Pr.61 or Pr.62 setting. (Refer to page 43 to 50.)
 (The X1, X2, X3 selection input terminal and STR terminal will change to the selected function.)

The terminals are screwless type, so prepare a small flat-bladed screwdriver (tip width 2.5 to 3mm) before wiring.

■ Protective function

The following protection functions are built in to protect the inverter. If the protective circuit functions, the inverter output will stop, alarm will display, and alarm signal will be output. The motor will coast to a stop. The inverter must be reset to resume operations.

Function name	Details	Display (Key pad)	
Overcurrent shut down	The protective circuit functions during acceleration, deceleration or constant speed when the motor output current exceeded approximately 200% of the rated current, and the inverter output stops.	During acceleration	OC1
		During constant speed	OC2
		During deceleration	OC3
Regenerative overvoltage shut down	The protective circuit functions when the DC voltage in the main circuit of the inverter exceeds the trip point with the regenerative energy during braking, and the inverter output stops.	OVT	
Overload shut down (Electronic thermal relay) (*1)	Motor The electronic thermal relay in the inverter detects overheating of the motor caused by overload or the additional heating at low speeds due to fan action, and stops the inverter output. Install a thermal relay on the output side of the inverter when using a 6 or more pole motor or when groups of motors are connected to one drive.	THM	

Function name		Details	Display (Key pad)
Overload shut down (Electronic thermal relay) (*1)	In-verter	The electronic thermal relay functions with the inverse time characteristic to protect the output transistor when 150% or more of the inverter rated output current flows but the overcurrent shut down is not activated (under 200%).	TH (THT)
External thermal relay input (*3)		System can be designed to prevent drive operation when external motor overload protector or thermoswitch in the motor opens on an overtemperature condition. Even if the relay contact is automatically restored, the inverter will not restart unless reset.	OH (OHT)
EEPROM breakage		The output will stop when the EEPROM which stores the parameter set values breaks.	PE (PE)
Stall prevention		When 150% (*2) or more of the inverter rated current flows to the motor during acceleration (or constant speed operation), this function stops increasing of frequency (or reduces frequency) until the load current decreases, to prevent the inverter from overcurrent tripping. When the load current has decreased below 150%, this function allows the inverter to return to and continue the previous operation. During deceleration, in contrast, if DC voltage in the inverter exceeds the rated value, this function stops reducing frequency to prevent the regenerative overvoltage shut off from being activated. When the regenerative energy becomes low, this function continues deceleration again.	OL (OLT) When stopped due to this function from a constant speed operation.

Function name	Details	Display (Key pad)
Insufficient voltage warning (* 4)	The control circuit will not function properly if the inverter power voltage drops, and will also cause an insufficient motor torque and increased heat generation. The inverter output will stop when the power voltage drops below approx. AC 115V. Operation will resume when the power voltage is restored to a correct value.	U U (UV)
Earth fault over current (* 5)	The protective circuit functions when a earth fault current has flowed due to a earth fault occurring in the output (load) side of the inverter. Activate only at a start of the operation. A earth fault occurring at low earth resistance may activate the overcurrent protection.	E F (GF)
In retry	Retry is executed when the retry function is selected, and that inverter alarm occurs. This indicates that the retry is functioning. (The display will show the time set in Pr.52 retry execution wait time.)	O P T (OPT)
Inverter stop by STOP key on key pad	When parameter No.75 is set to 14 and motor is stoped by using the stop key in external operation mode, "E. O" is displayed. An alarm signal will not be output. (Refer to page).	E O (EO)

(Note)

- * 1. The heat cumulative data in the electronic thermal relay will be cleared when the inverter is reset.
- * 2. The stall prevent operation current can be set. The default setting is 150%.
- * 3. This functions only when the function "external thermal relay input selection" is set.
- * 4. An alarm signal will not be output when this protective function activates. If the voltage is insufficient (main circuit DC voltage is 230V or less) when the power is turned on, "0.0" will display for approximately 10 seconds and then the insufficient voltage display "U_U" will appear. (No key pad operation will be accepted during the display of "0.0".) If the main circuit DC voltage is higher than standard tolerance when the power is turned on, the display "F_U" will appear, and if the voltage does not lower within 10 seconds, the display "O_Uf" (overvoltage shut down) will appear.

- **Retention of alarm output signal**

If the no-fuse breaker on the inverter's power supply side is turned OFF when the protective function activates, the inverter control power supply will be lost, and the alarm output will not be held. If the output must be held, create a sequence that will hold the alarm output signal with an external equipment.

- **Alarm display**

The display on the key pad will automatically change when the protective function operates. (Only during monitoring.)

- **Resetting methods**

The inverter output stop state will be retained if the protective function operates, and the inverter will not restart unless it is reset. Turn the power off and on once or press the RESET key on the key pad. If the RES terminal is set with Pr.60, Pr.61 or Pr.62 (input terminal function selection), resetting will be possible by opening reset terminal RES-P24 after short-circuiting for approximately 0.1 second or more.

If the short circuited state between terminal RES-P24 is continued, "FrU" will display (light) and indicate that the reset state has been entered.

8. DIMENSIONAL OUTLINE DRAWING

■ FR-U120S-N - EC

0.2 to 0.4K Installation screw M4 (3 places)

(Unit : mm)

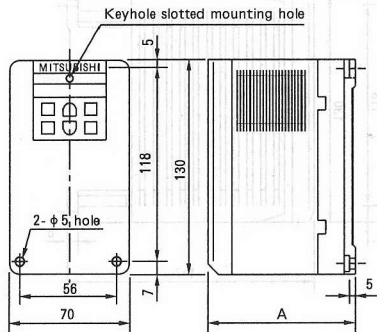

Keyhole slot dimensions



Capacity	A
0.2K	101
0.4K	141

0.75K

Installation screw M4 (4 places)

(Unit : mm)

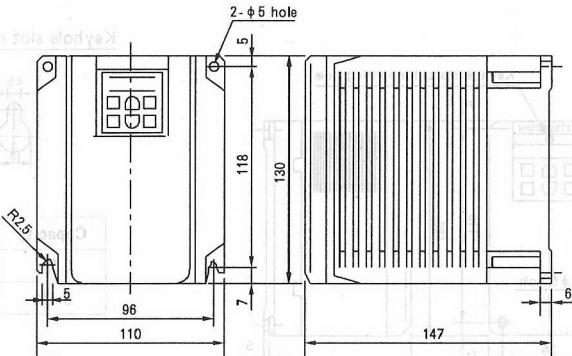
**(Note)**

For 0.75K drive, heatsink is standard on the left and right and it will get HOT at heavy loads.

9. SELECTION OF PERIPHERAL DEVICES

■ Selection of peripheral devices

Motor output (kW)	Applicable inverter model	No-fuse breaker (NFB) or Leakage breaker (NV)	Magnetic contactor (MC)			Wiring (mm ²) (Note) 4		EMC FILTER REF.
			A area	B area	C area	R, S, T	U, V, W	
0.2	FR-U120S-N0.2K-EC	NF30 model, NV30 model 10A	S-K18	S-K21	S-K21	2	2	SF1320
0.4	FR-U120S-N0.4K-EC	NF30 model, NV30 model 10A	S-K21	S-K25	S-K50	2	2	SF1320
0.75	FR-U120S-N0.75K-EC	NF30 model, NV30 model 15A	S-K21	S-K25	S-K50	2	2	SF1321

(Note)

1. Select the NFB model according to the power supply capacity.
2. The wiring sizes are shown for a 20m length.
3. When installing an MC on the inverter power supply, select the applicable range A, B, or C shown on the right according to the power source capacity and wiring length.
4. Use a $\phi 0.4$ to $\phi 1.0$ solid wire or 0.3 to 0.75mm² stranded wire for the control line.

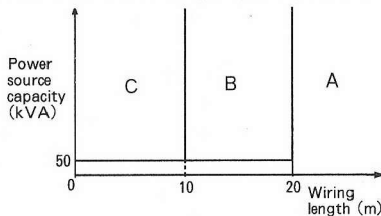

(Note)

Use the wire sizes recommended above.

- An excessive peak current will flow to the power supply input circuit when the inverter is directly connected to a large capacity power supply transformer (500kVA or more, wiring 10m or less), and the inverter may be damaged. Always install the optional power factor improvement reactor FR-BAL in this case. (Use the one rank large size.)

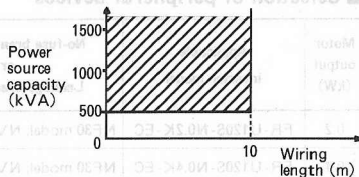

- The wiring length between the inverter and motor must be less than 100m. The control line must be 30m or less and must be separated from the main power line. Use a twisted pair wire when inputting the frequency signal from an external source.

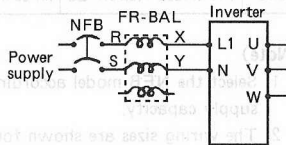

10. OPTION

Name (Model)	Specifications and construction									
	Filter type	Inverter	Dimensions			Installation screw	Weight (kg)	Loss (W)	Leakage Current (mA)	Rated Current (A)
			W	W1	D					
SF1320	FR-U120S-N0.2K/N0.4K	70	56	30.5	M4	0.32	2.7	10	6	
SF1321	FR-U120S-N0.75K	110	96	36.5	M4	0.52	3.8	10	10	

Mains conducted emissions filter

Screwless terminals

[Unit : mm]

KEYWAY

5

8

10

Specifications

Rated Voltage : AC250V

Rated frequency : 50/60Hz

"WARRANTY"

1. Exceptions to the warranty, such as opportunity losses

We do not warrant to reimburse you or your customers for opportunity losses, damage to produce other than ours, or any other business which results from the failure of our product, whether such a failure has occurred within the free warranty period or not.

2. Repair after production stop

If we stop producing any of our models (products), we will continue to repair such a model for seven years after the month of the year when its production is stopped.

3. Delivery condition

It is understood that a standard product which does not include setting and/or adjustment in applications is delivered when it arrives on your premises, and we are not obliged to adjust or test run such product on the spot.

Application of this product

- This product is not designed or manufactured for use with any equipment or system which will be operated under conditions hazardous to life.
- If you are planning to use this product in any specific application such as passenger medical, aerospace, atomic, power or submarine equipment or system, please refer to our business department.
- This product is manufactured under rigorous quality control. However, safety devices should be installed if this product is applied to any facility that may result in a serious accident or loss due to a failure of this product.
- This product should only be used with a three-phase induction motor load.

Addendum to FR-U120S-EC manual IB(NA) 66719-A (9609)

Additional Information

Motor Earth

Connect the motor earth to the panel (cabinet) earth point of the inverter.

The minimum wire size for earthing is 2mm^2

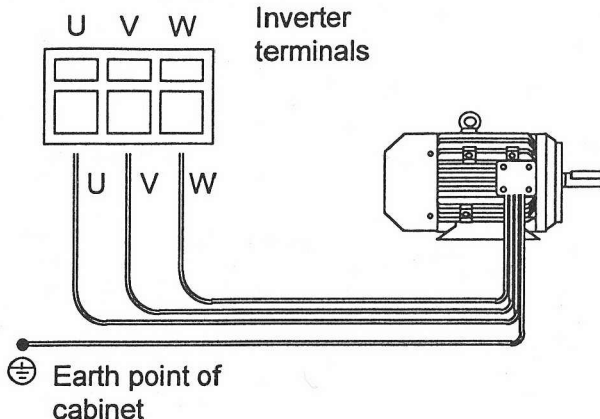

Additional Information

On page 10 of the report, the author states that the results of the experiment were not statistically significant.

Figure 1

Figure 2

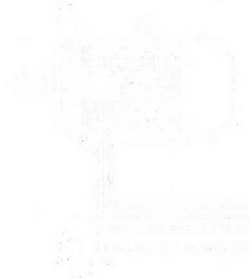

Revision

Publication date	Instruction manual No.	Details of revision
SEPT. 1996	IB(NA)66719-A	First edition



MITSUBISHI ELECTRIC CORPORATION

HEAD OFFICE:MITSUBISHI DENKI BLDG. MARUNOUCHI TOKYO 100 TELEX:J24532 CABLE MELCO TOKYO

TYPE	FR-U120S-EC EIBUN TORISETU
CODE	1A2H09

IB(NA)66719-A(9609) ROD Printed in Japan

Specifications are subject to change without notice.